



PALAZZO BRASCHI PROGETTO DI RIALLESTIMENTO



Totem analogico

Piano secondo : n. 15

Piano terzo : n. 7

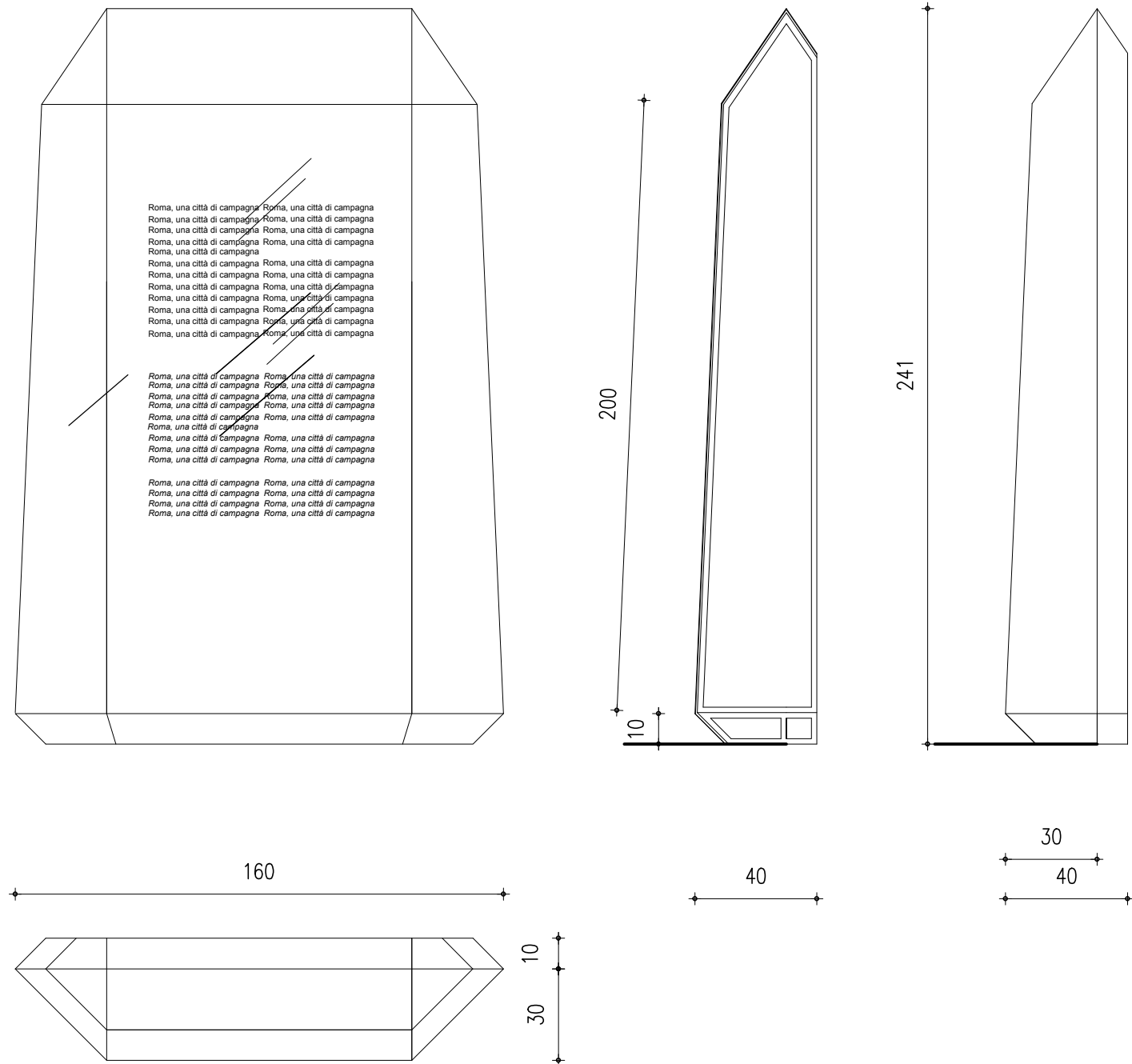

Postazione per sala

sala E-3 -
L'urbe, le vie, le

sala E-6 -
Cerimonie e rituali

sala E-9 -
Giardini

sala I - 3 -
I volti dei protagonisti

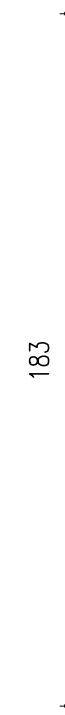
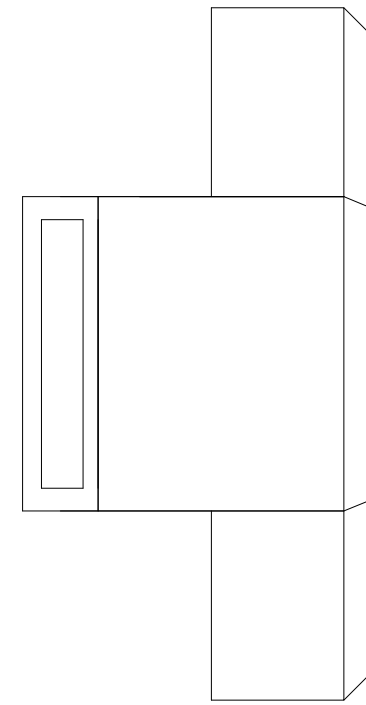
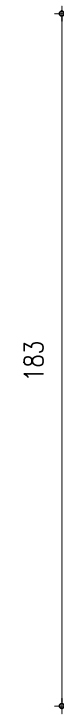
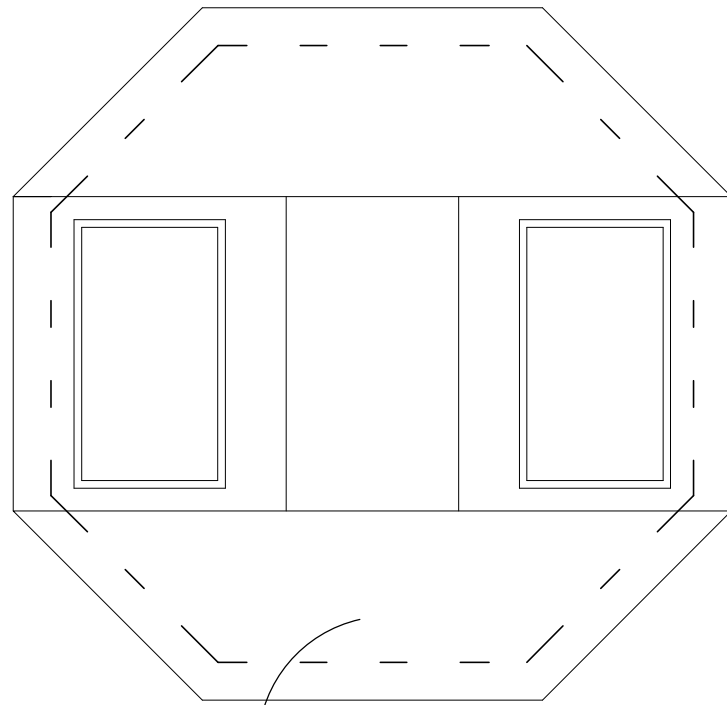
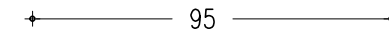
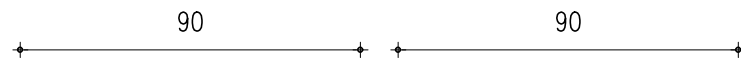

SEDUTA

46

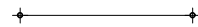

190

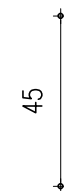
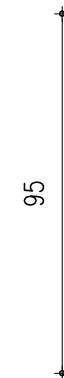
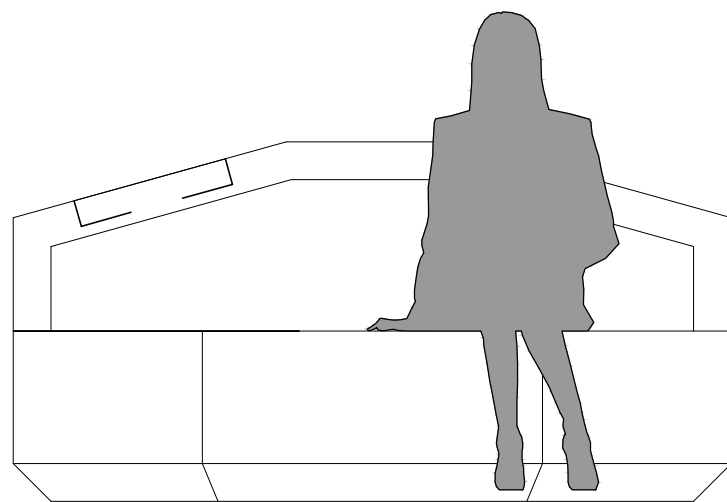
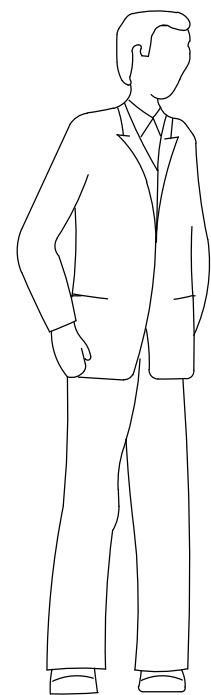

Postazione per sala "Crocevia"

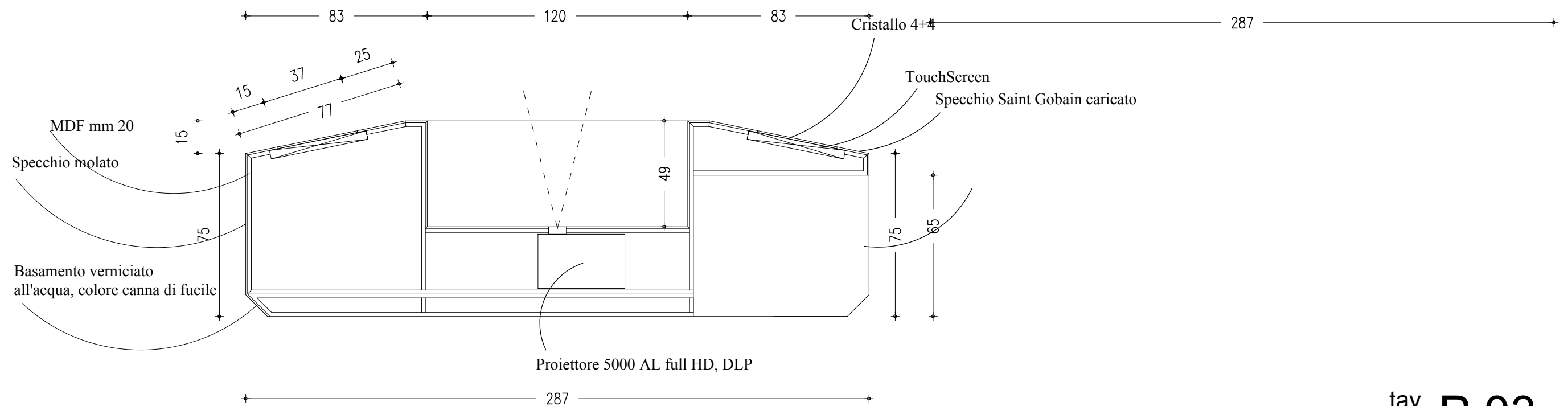
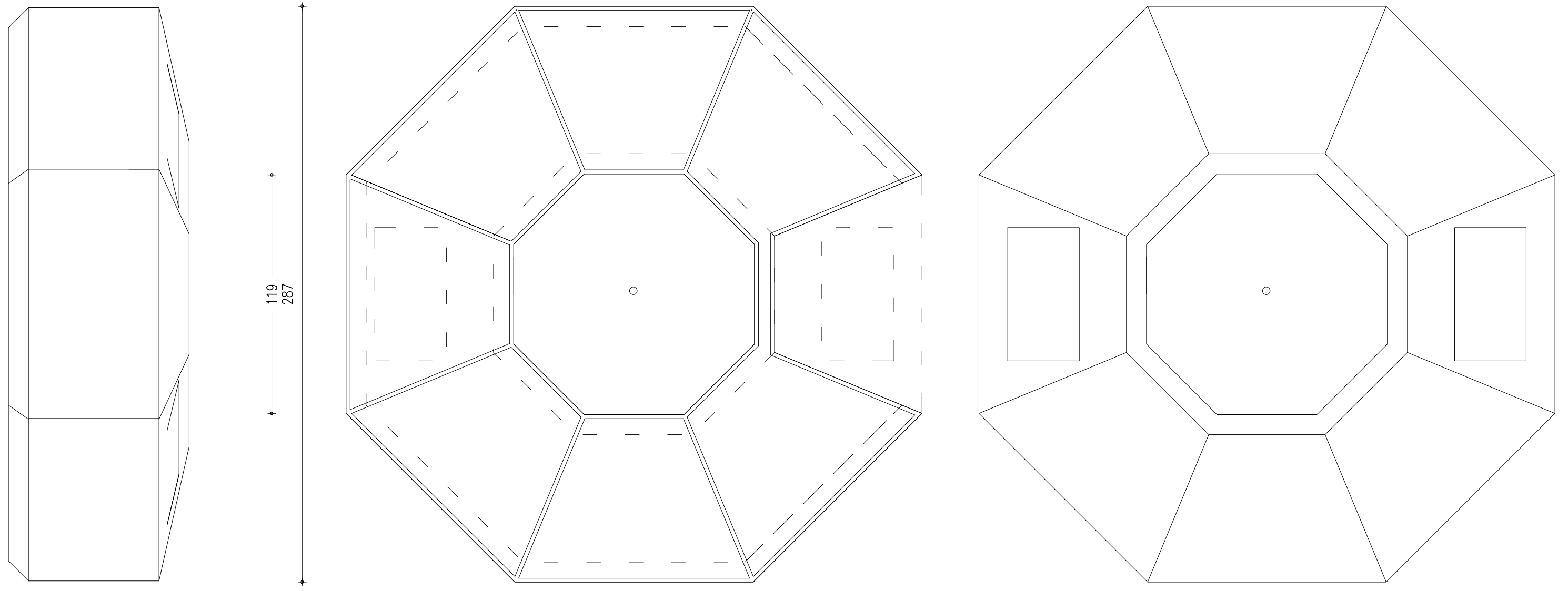

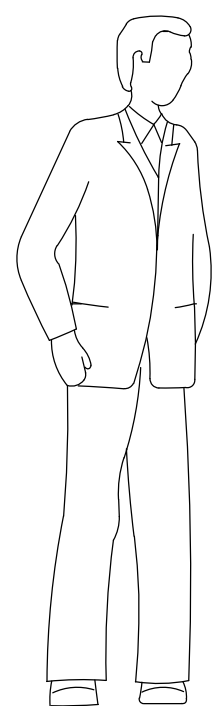

Superficie specchiante

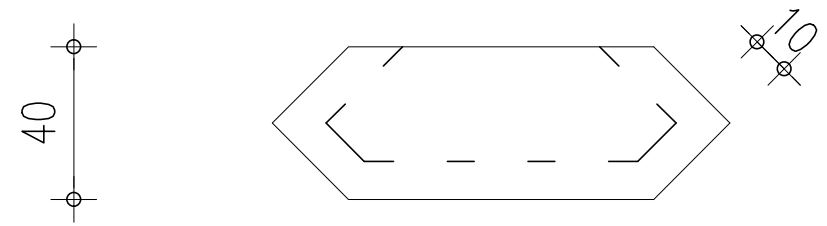
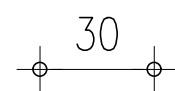
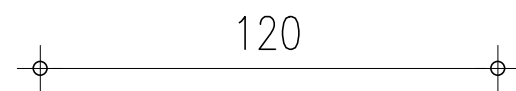
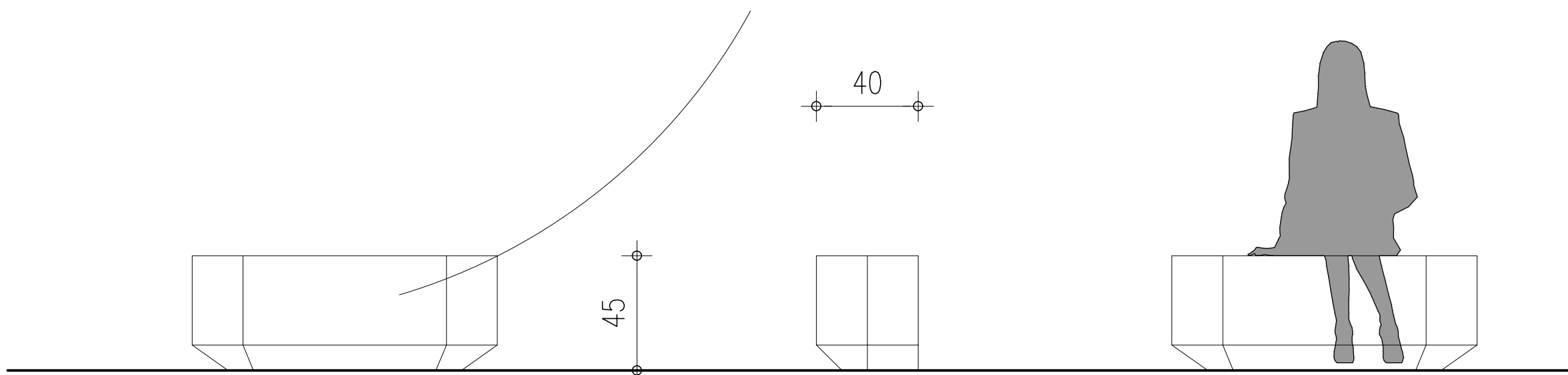

Seduta sala



Vetrina ritrovamenti ceramici (voce 1.8.1)

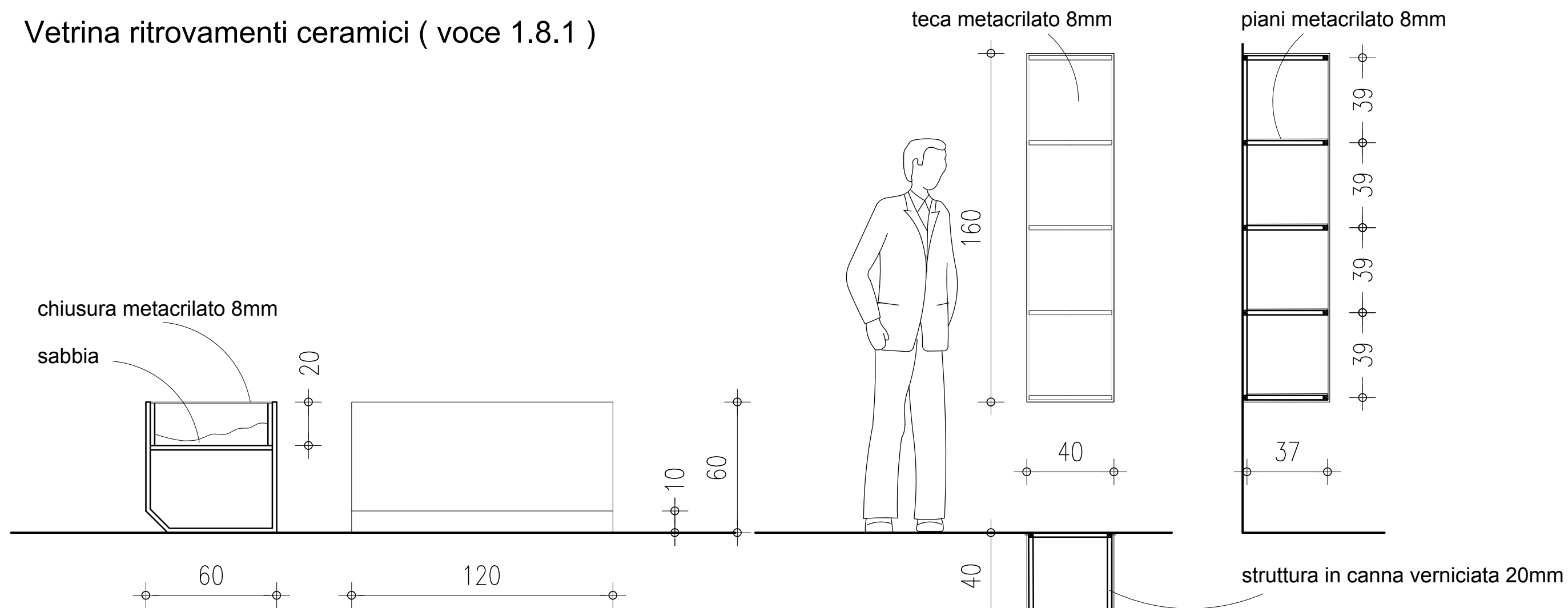

Vetrina ritrovamenti ceramici (voce 1.8.2)

Vetrina (voce 2.2)

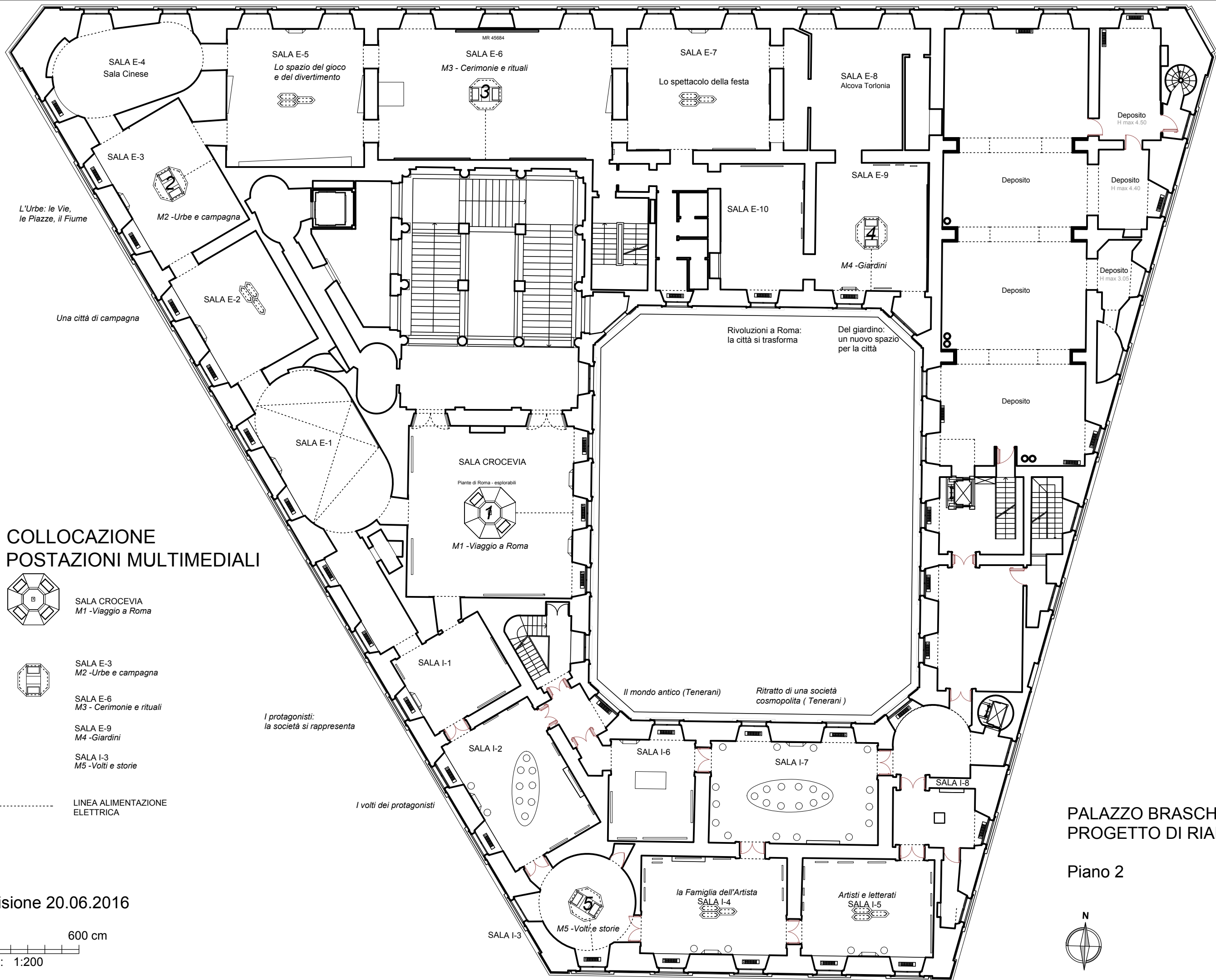

**COLLOCAZIONE
POSTAZIONI MULTIMEDIALI**

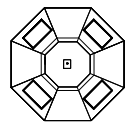

SALA CROCEVIA
M1 - Viaggio a Roma



SALA E-3
M2 - Urbe e campagna

SALA E-6
M3 - Cerimonie e rituali

SALA E-9
M4 - Giardini

SALA I-3
M5 - Volti e storie

LINEA ALIMENTAZIONE
ELETTRICA

revisione 20.06.2016

0 600 cm
rapp: 1:200

**PALAZZO BRASCHI
PROGETTO DI RIALLESTIMENTO**

Piano 2



tav. **02.0**

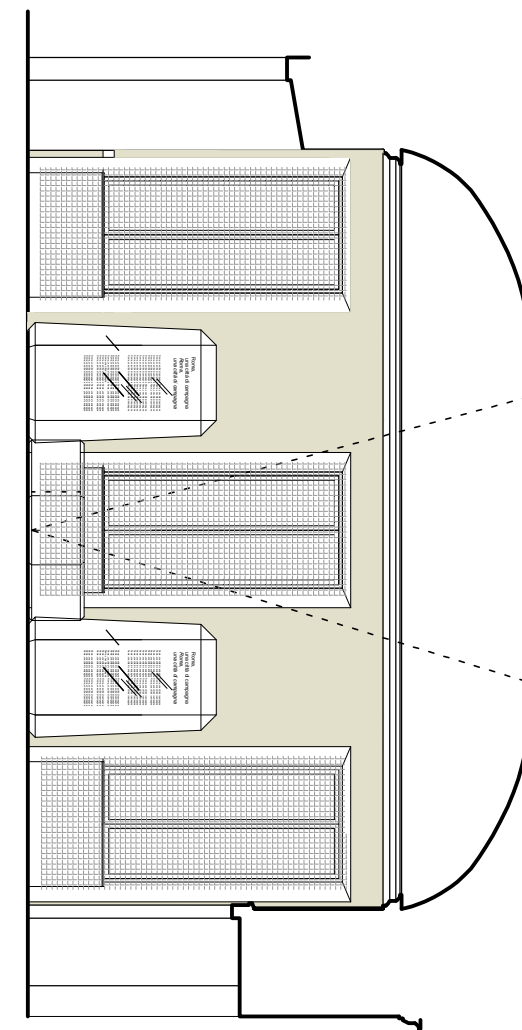
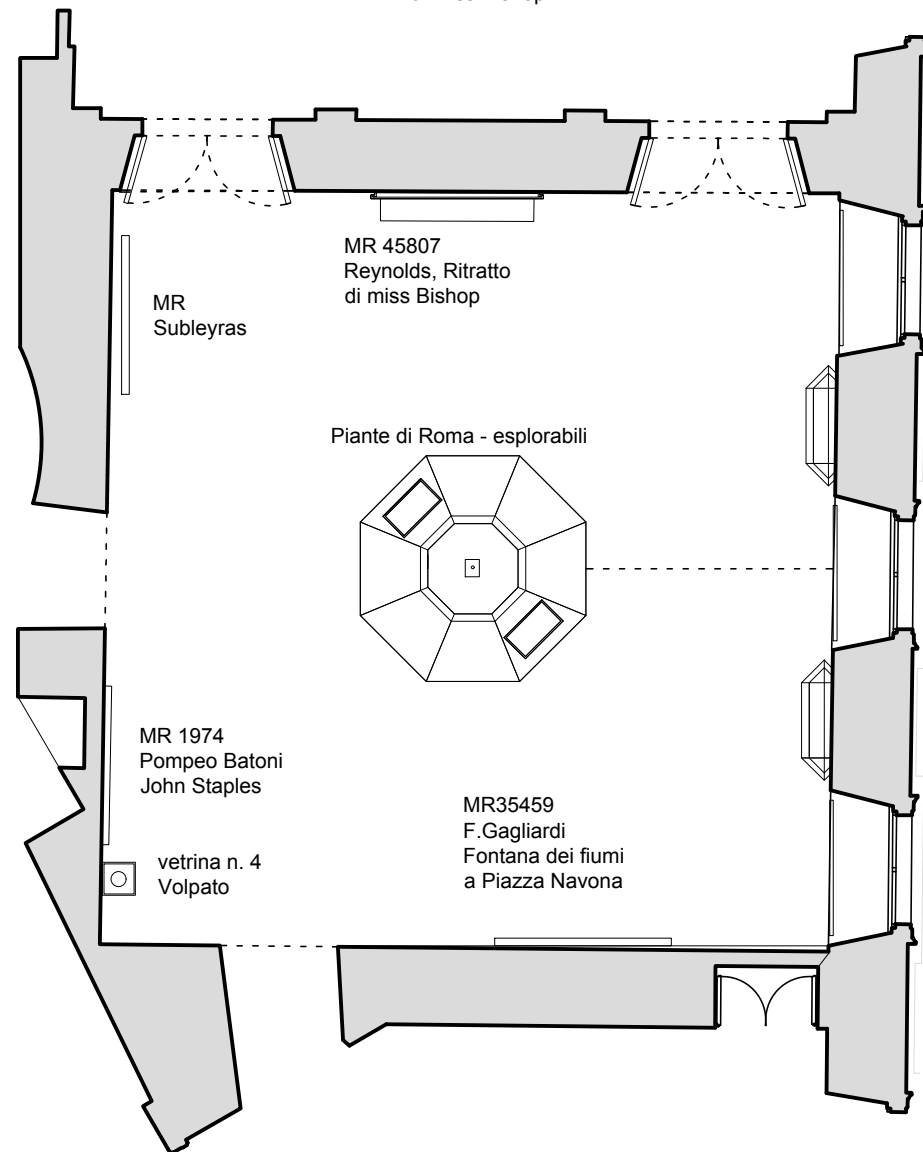
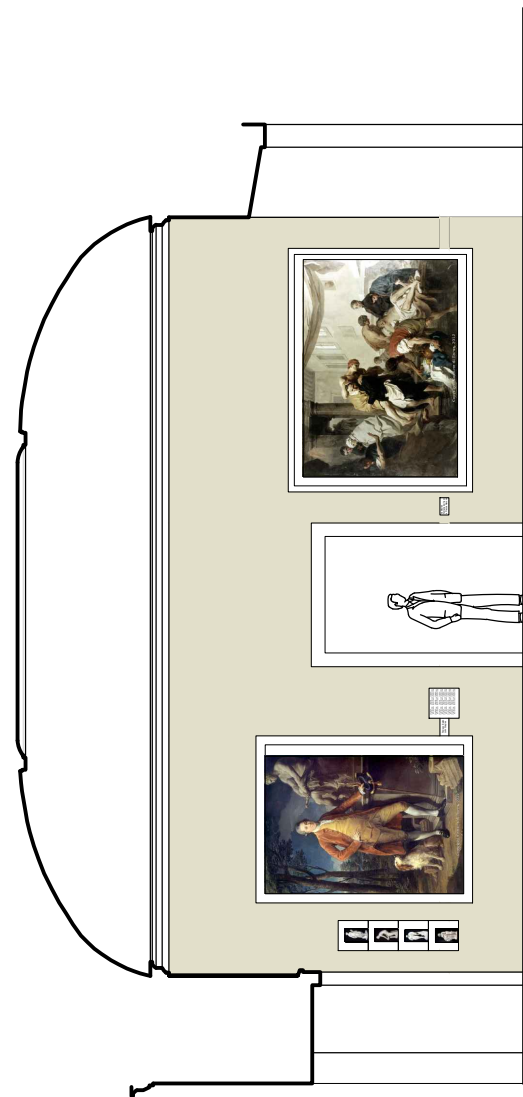
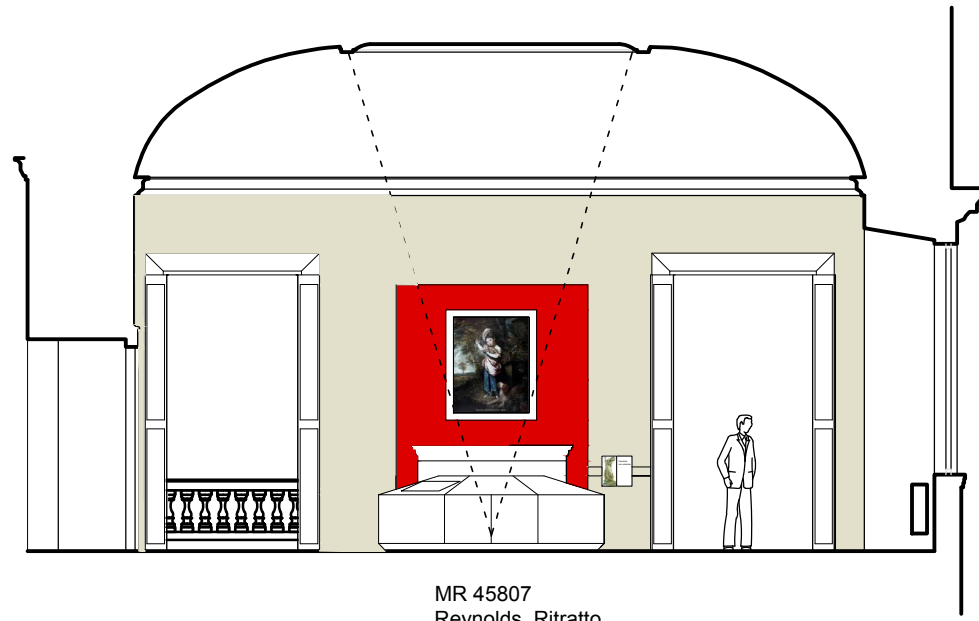

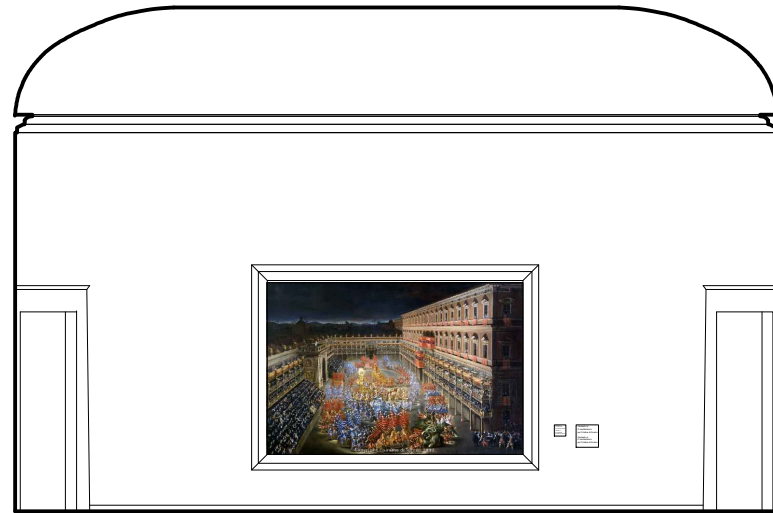

MR 5698
Carosello a P.zza Barberini
per Cristina di Svezia

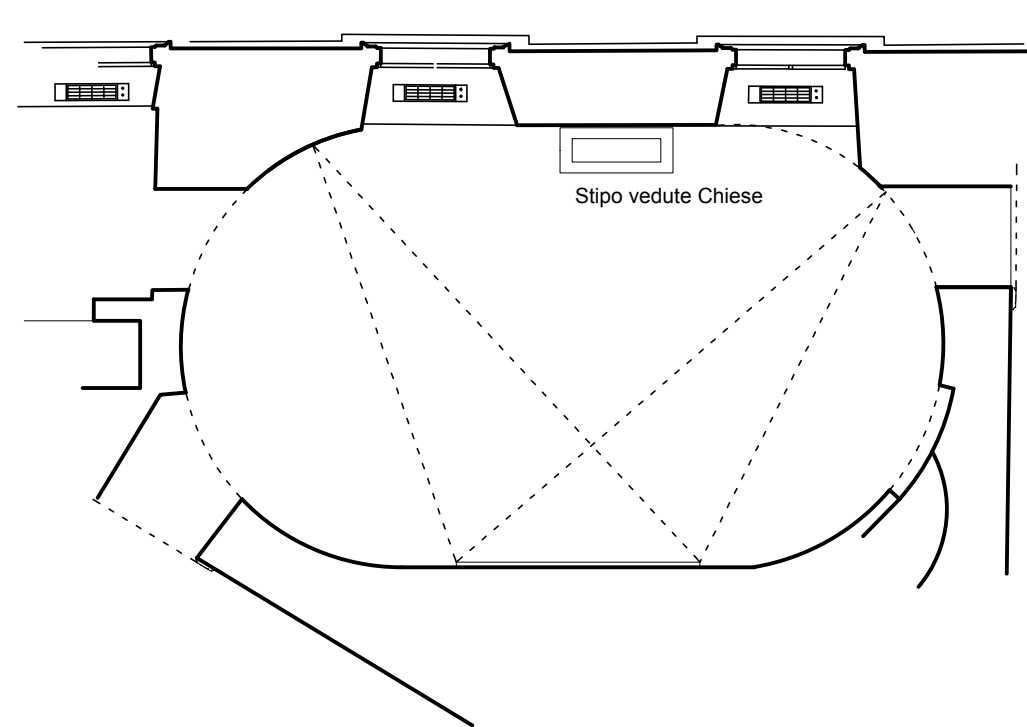
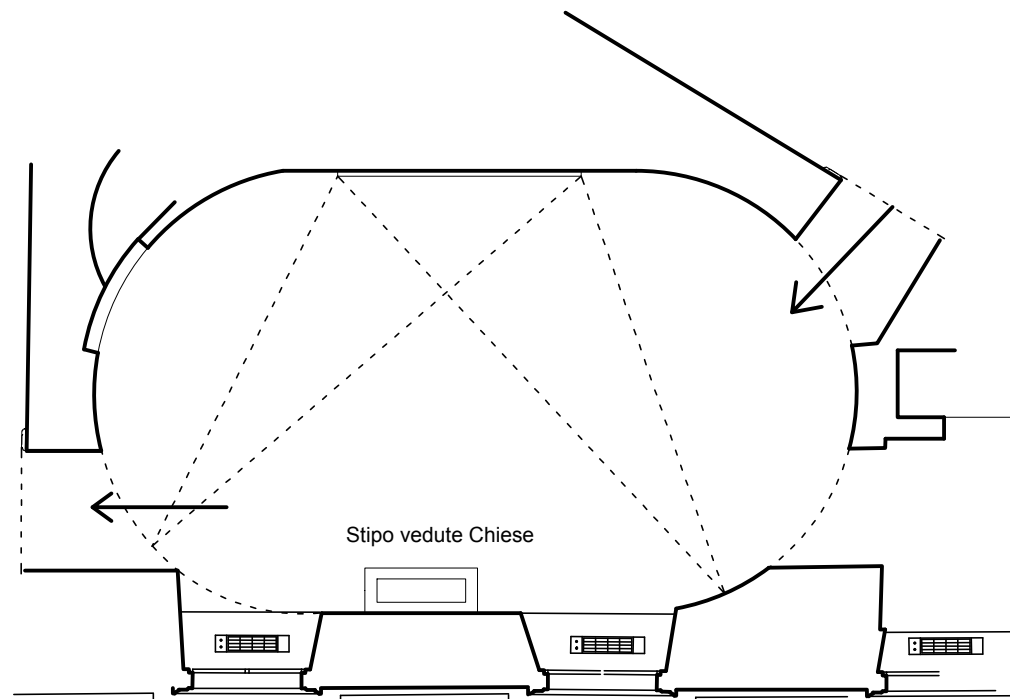
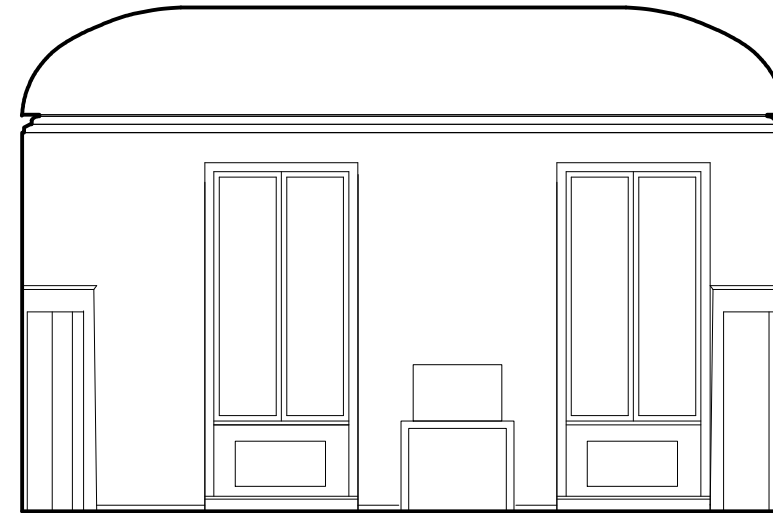

Nota: sala al buio, solo una illuminazione mirata sul carosello.



MR 22147
MR 7060 MR 4041 MR 1915
MR 8812 MR 350 Dep MC 144

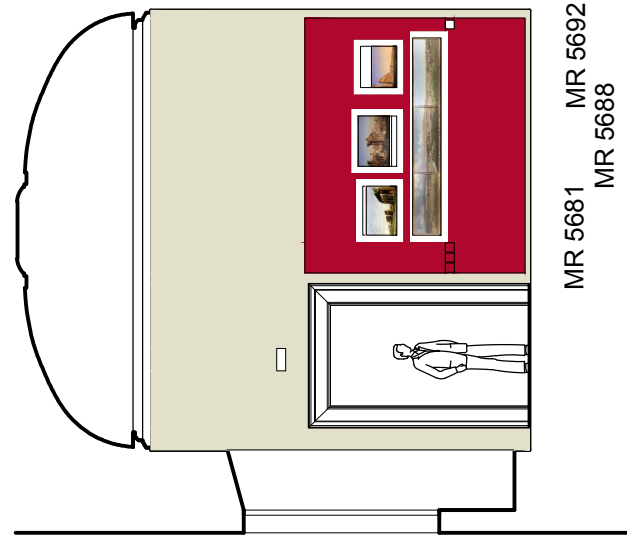

MR 5681 MR 5692
MR 5688
MR 4214

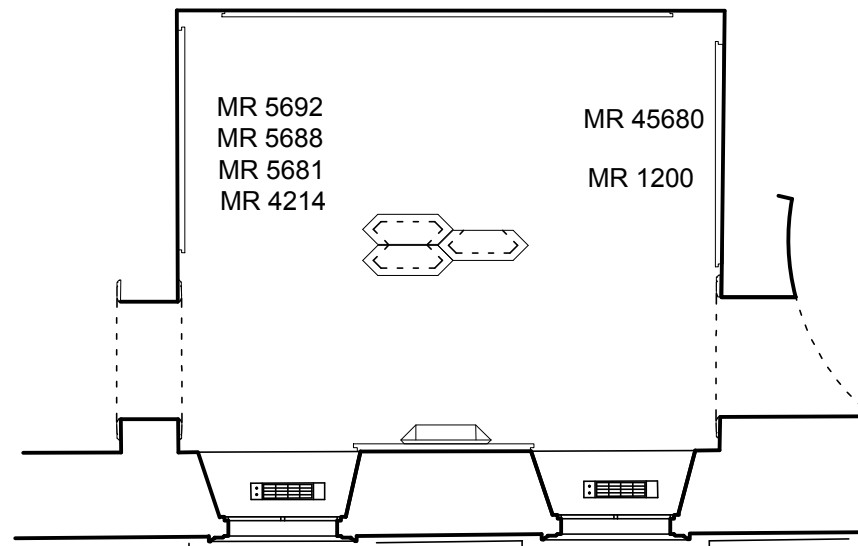

MR 5692 MR 45680
MR 5688
MR 5681 MR 1200
MR 4214

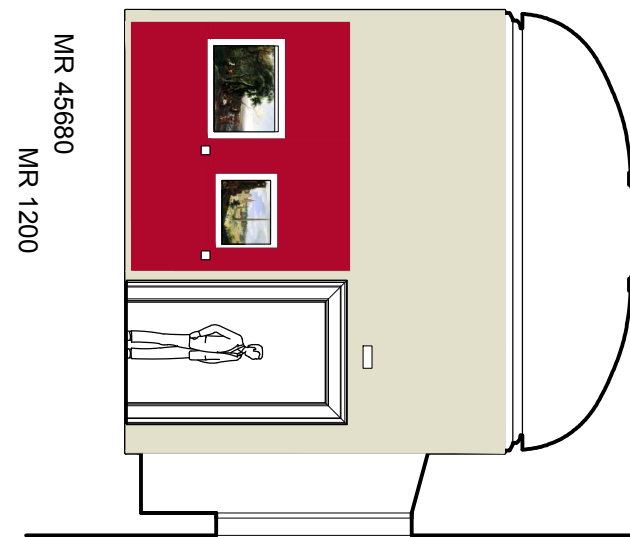

MR 45680
MR 1200

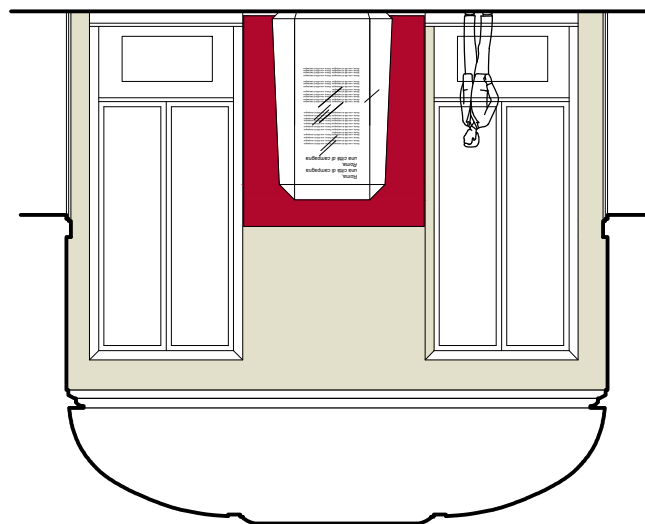



MR 4086
MR 167

MR 5680
MR 5683

MR 45731

MR 1985
MR 1281

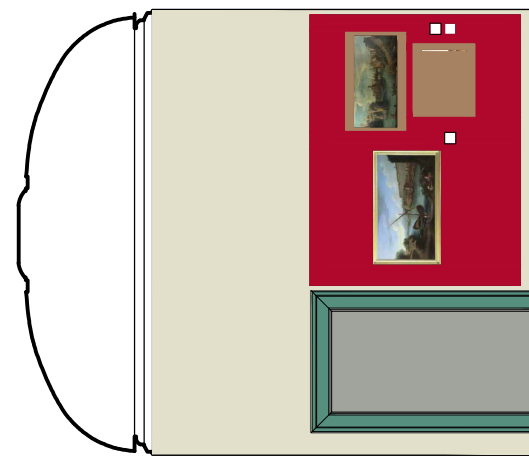

MR 49234

Dep PV 108
MR 947

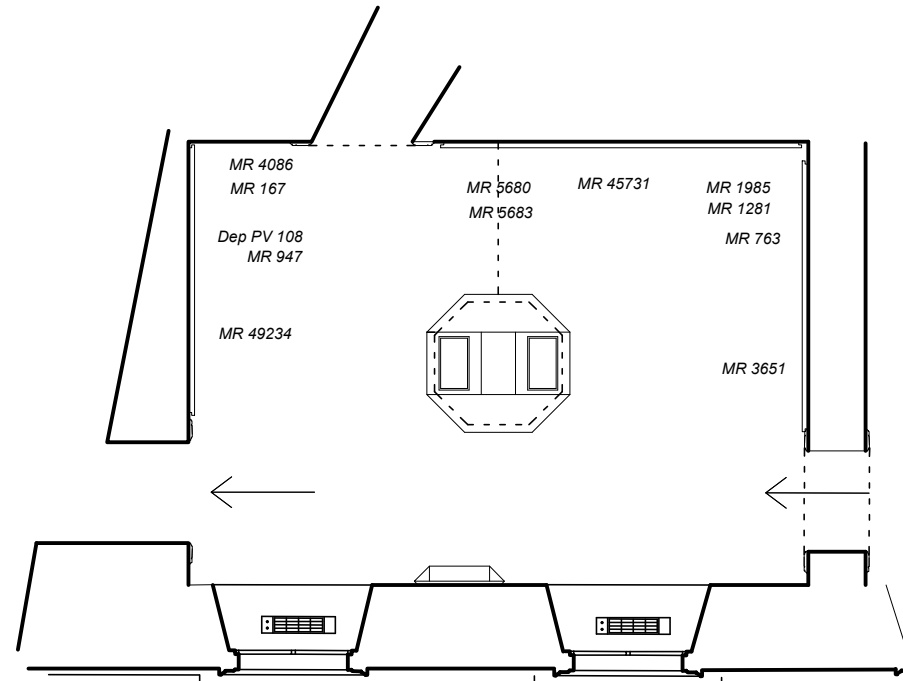

MR 4086
MR 167

Dep PV 108
MR 947

MR 49234

MR 5680
MR 5683

MR 45731

MR 1985
MR 1281

MR 763

MR 3651

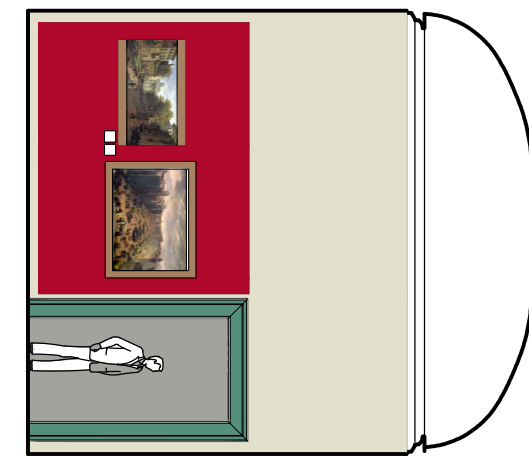

MR 763

MR 3651



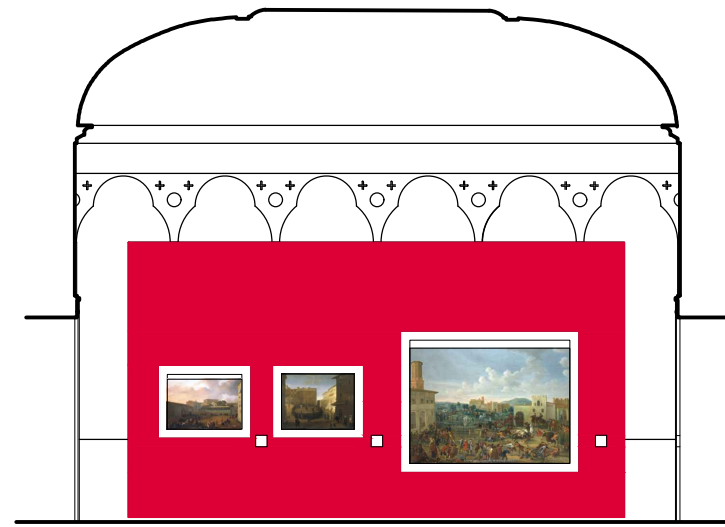

MR 597 MR 45819 MR 594

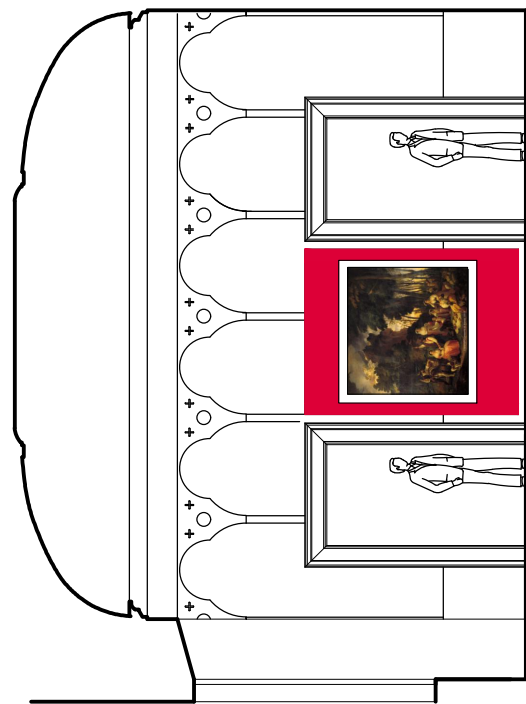

MR 3390

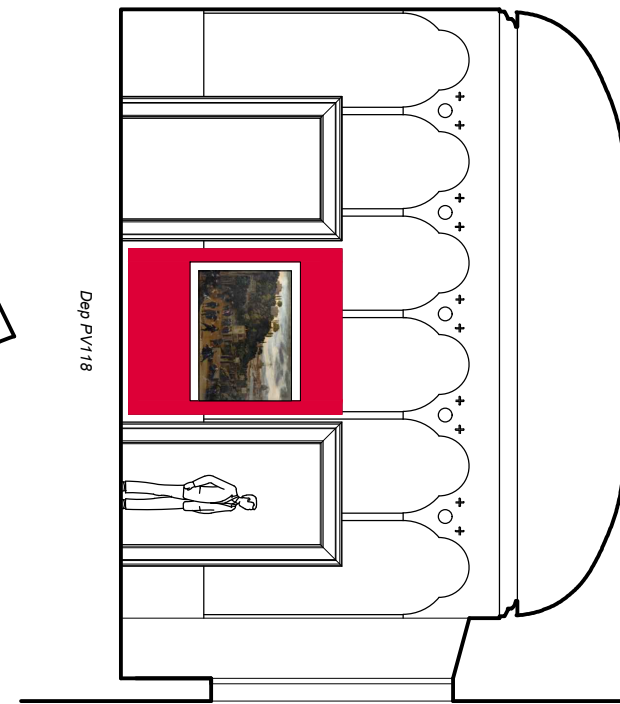
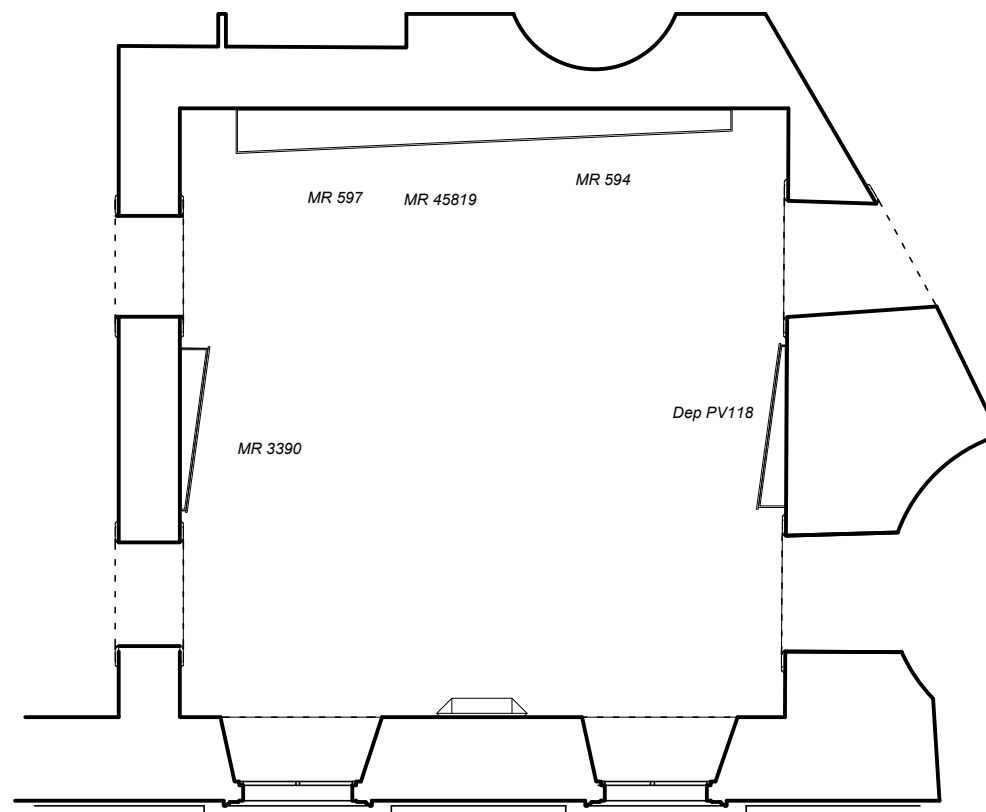

Dep PV118

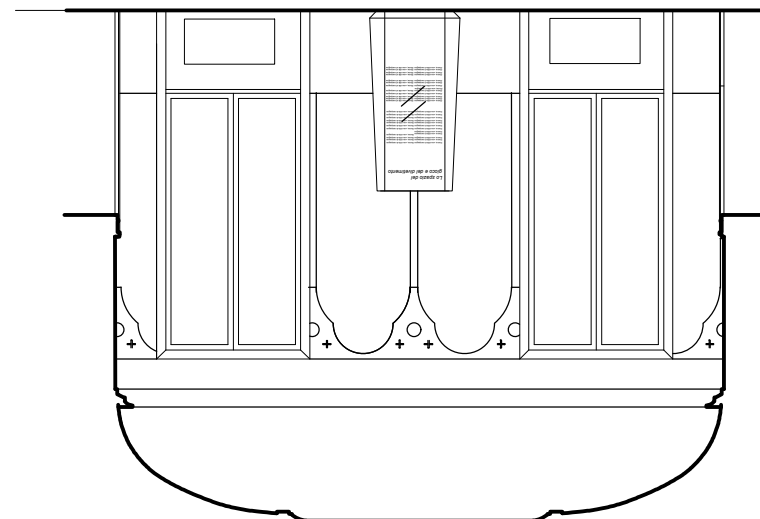

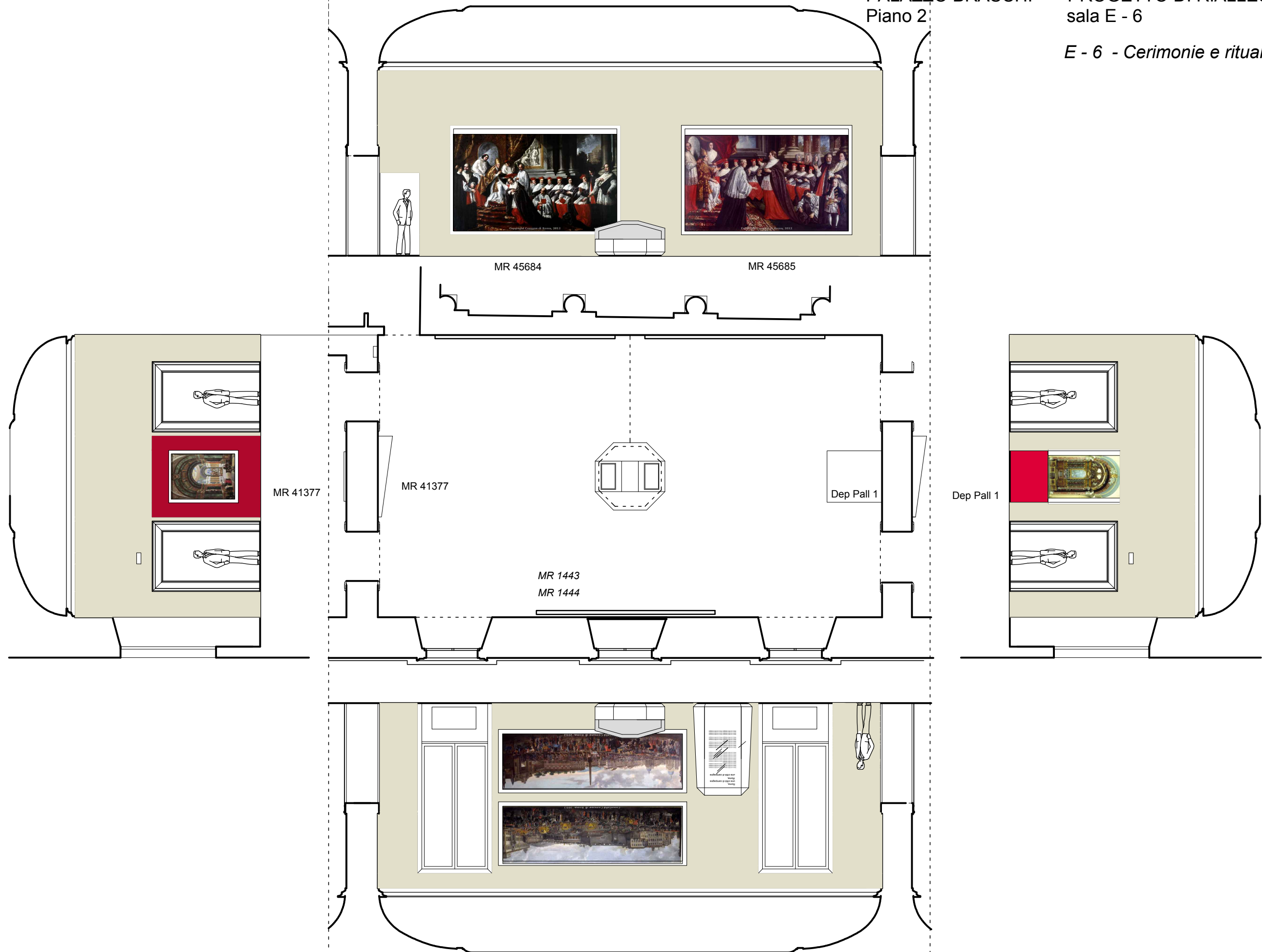



MR 5699
Giostra saracino

MR 4218 -Pinelli
MR -Pinelli

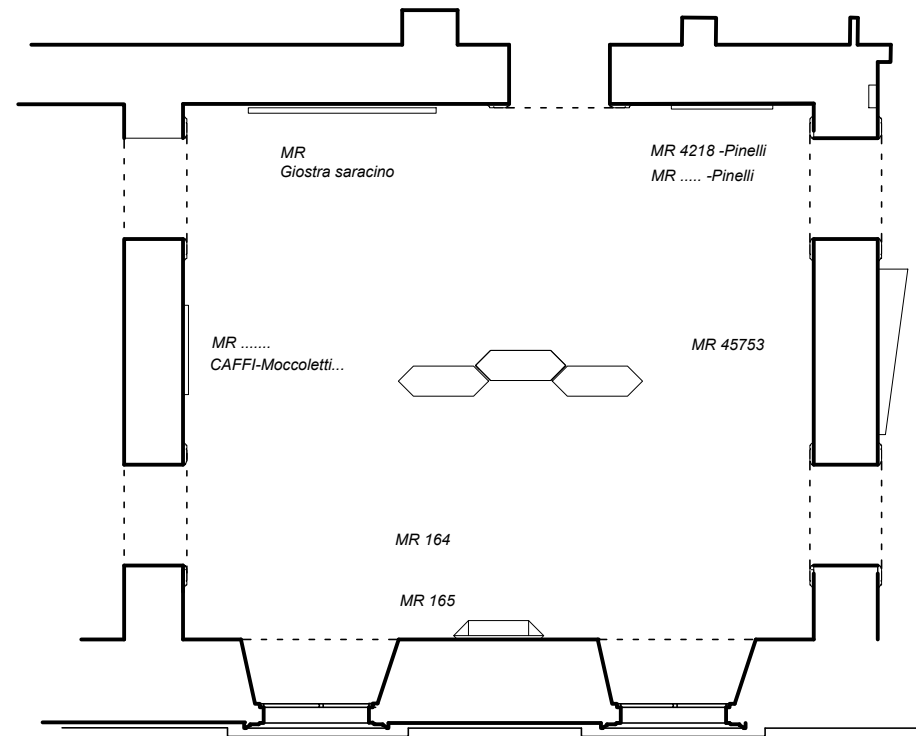
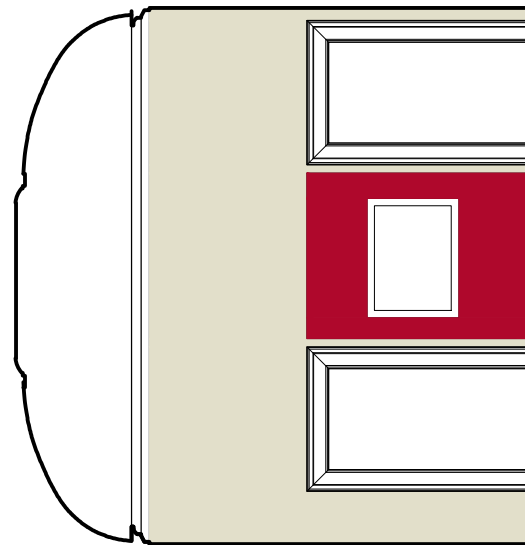

MR
Giostra saracino

MR 4218 -Pinelli
MR -Pinelli

MR
CAFFI-Moccoletti...

MR 45753

MR 164

MR 165

MR 45753

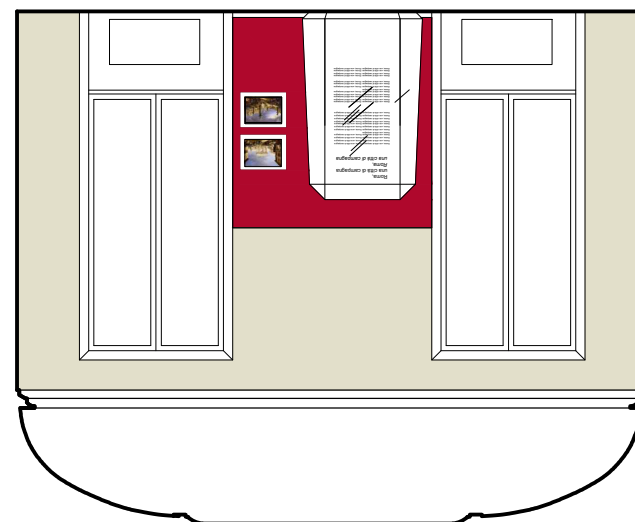
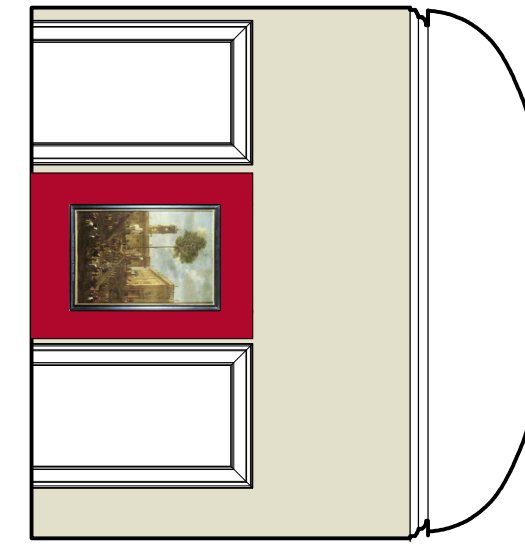

Del giardino: un nuovo spazio per la città

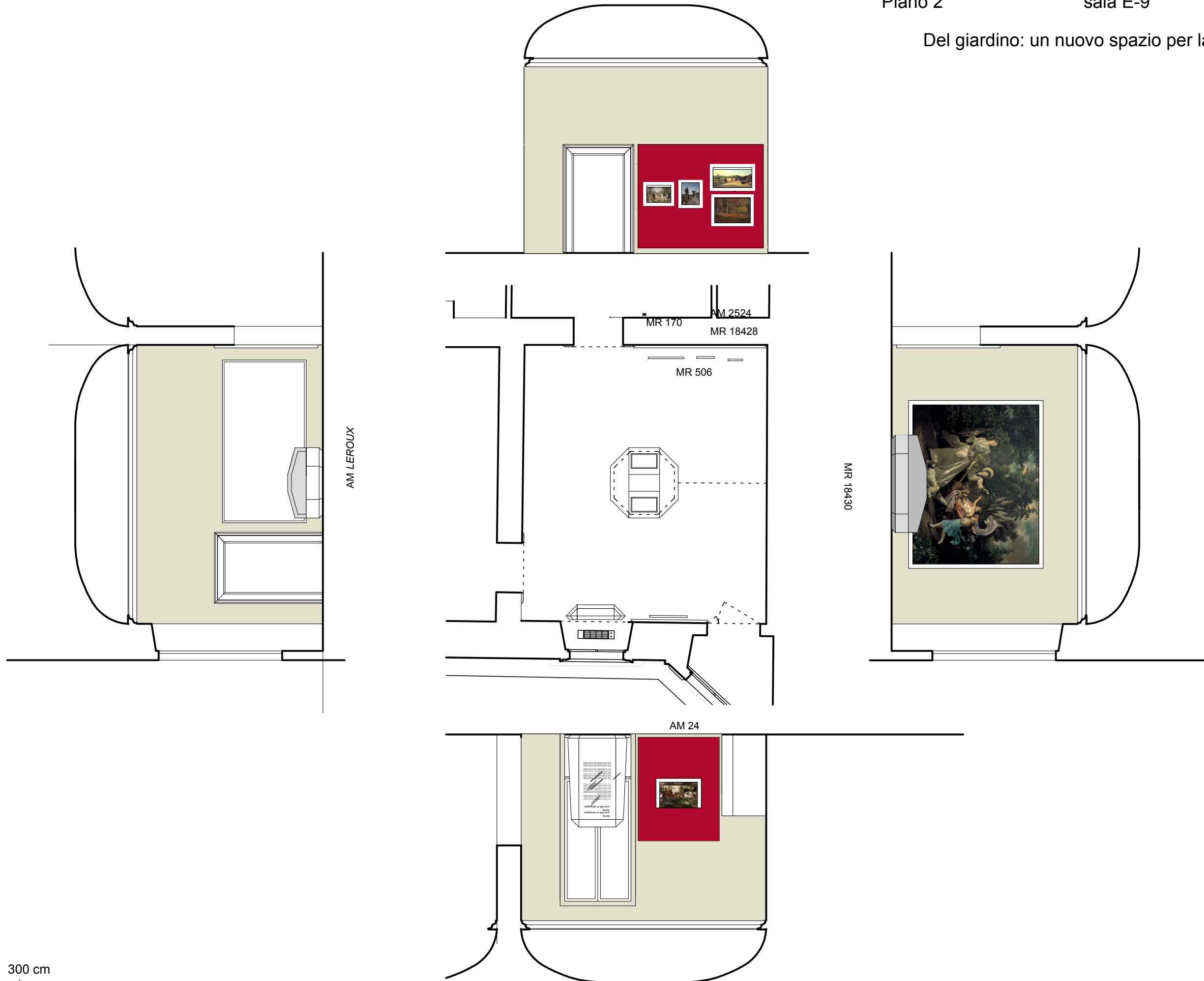

0 300 cm
rapp: 1:100

aggiornamento :04/07/2016

tav. 2.8

Collezione Apolloni

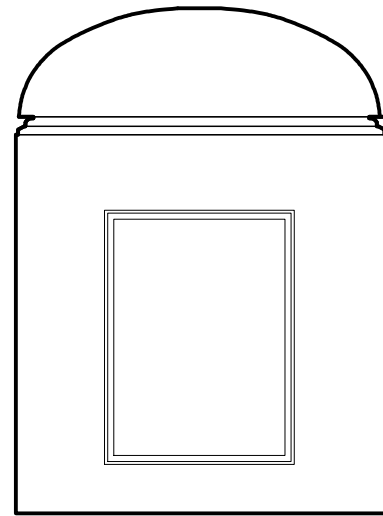

Transi

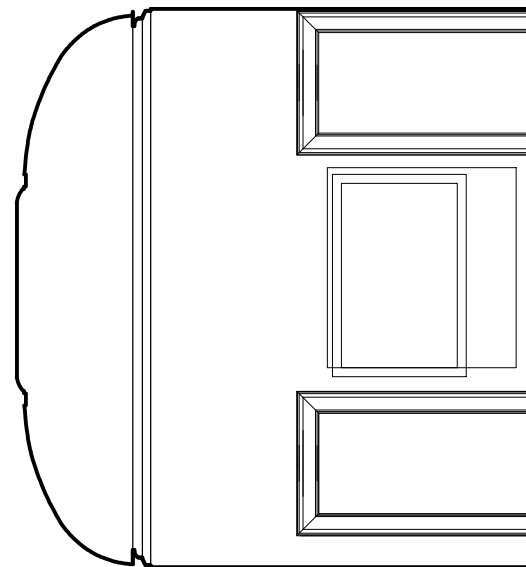

Thomas
Garibaldi all'assedio
di Roma

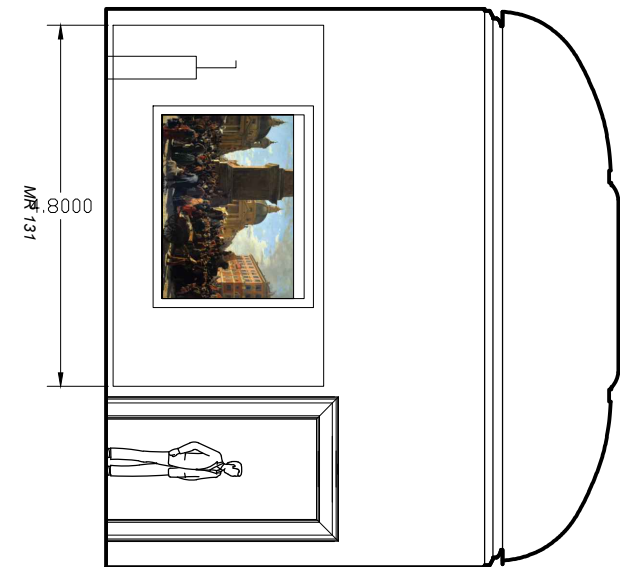
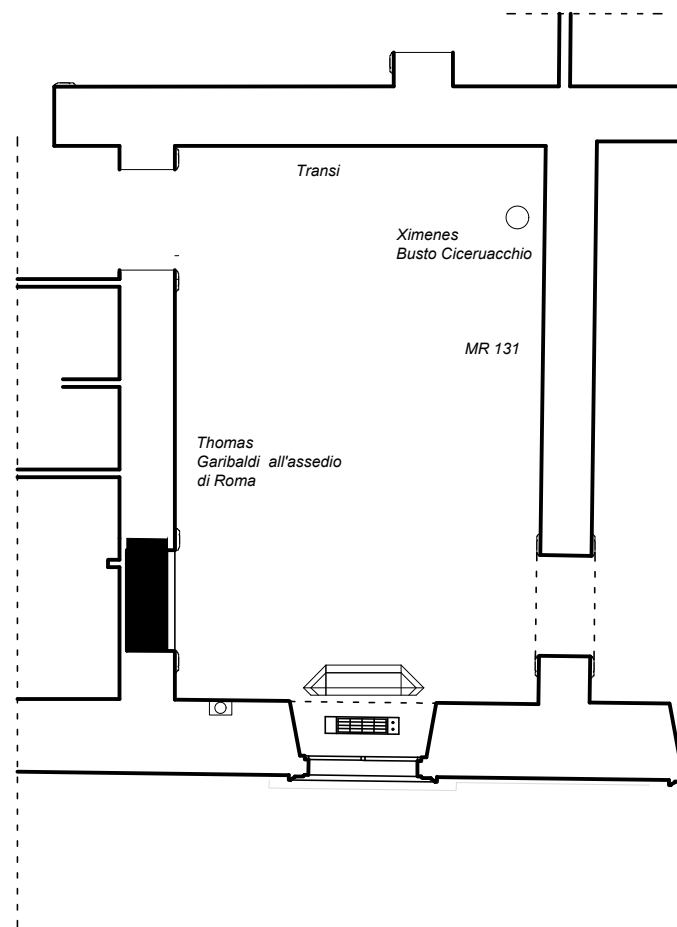

MR 164



MR 165

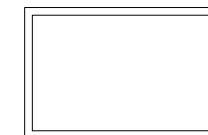

Thomas
Garibaldi all'assedio
di Roma



MR 765

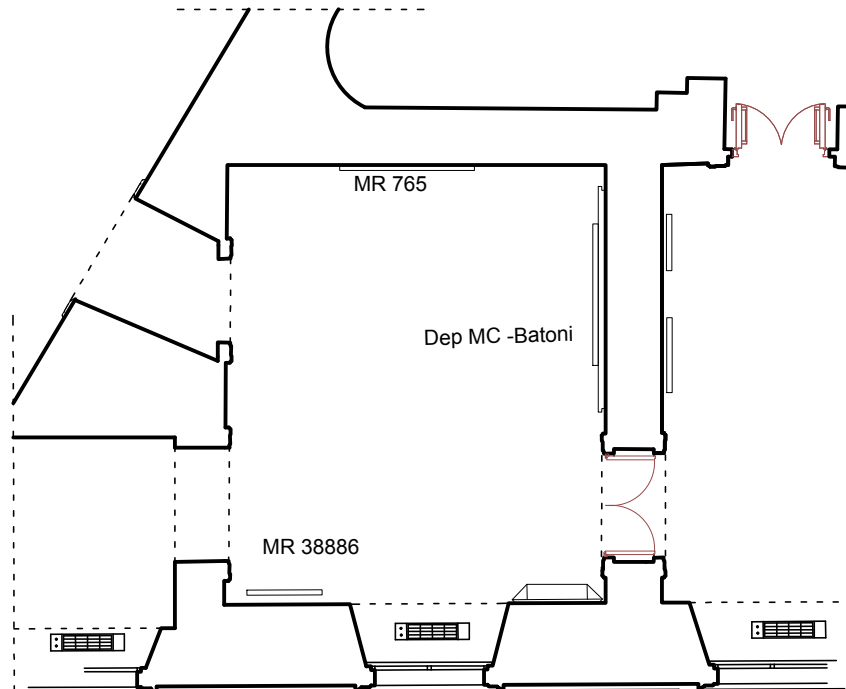
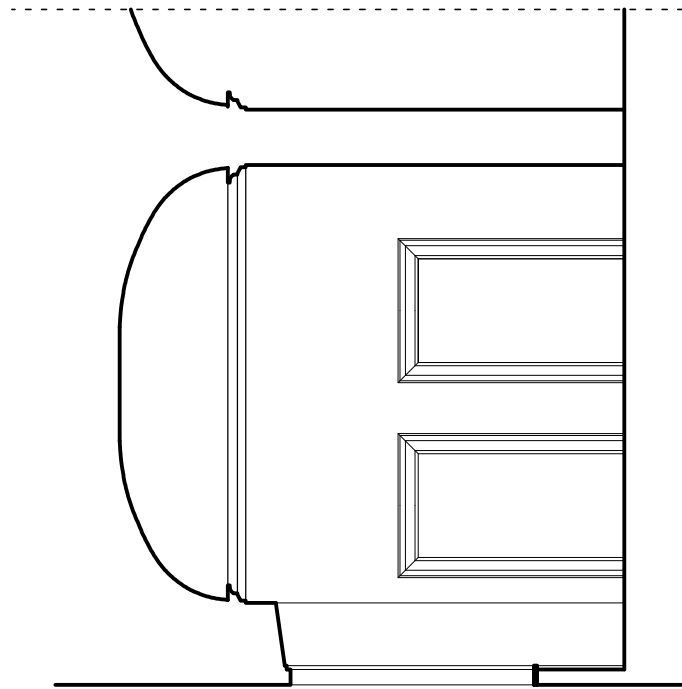

Dep MC -Batoni

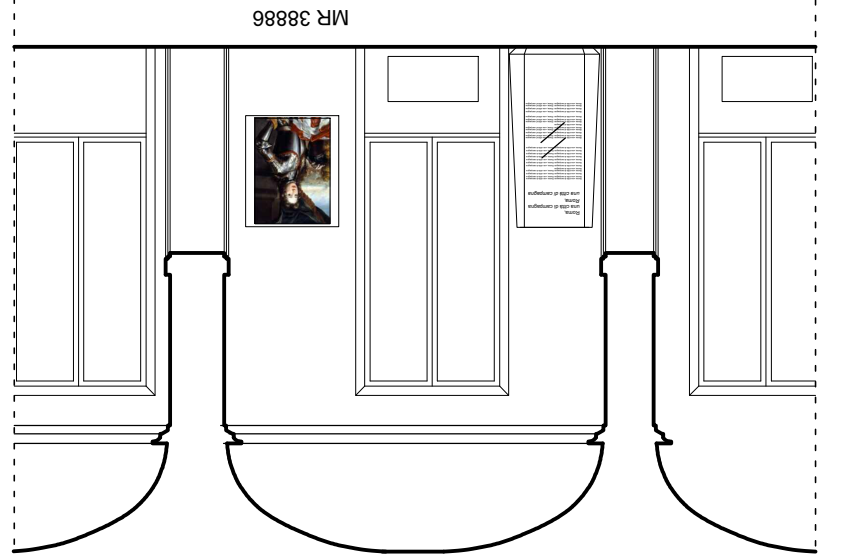
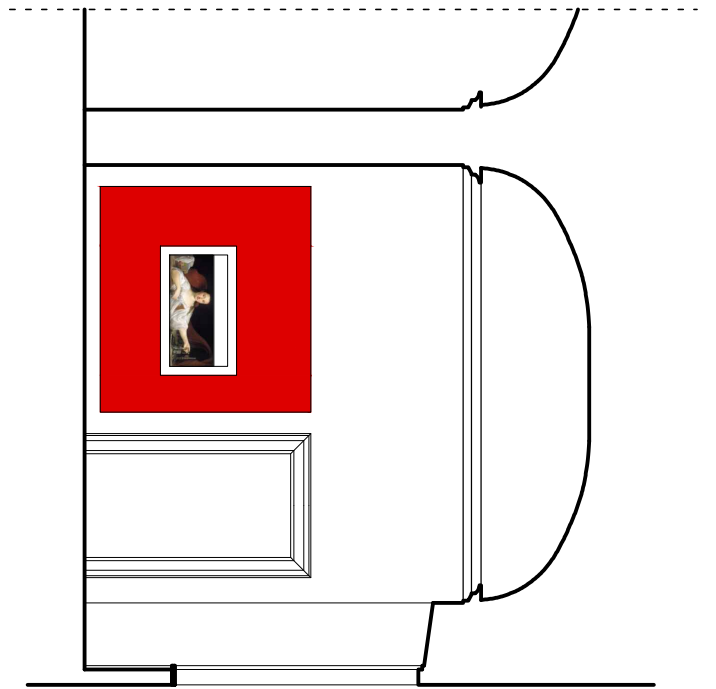

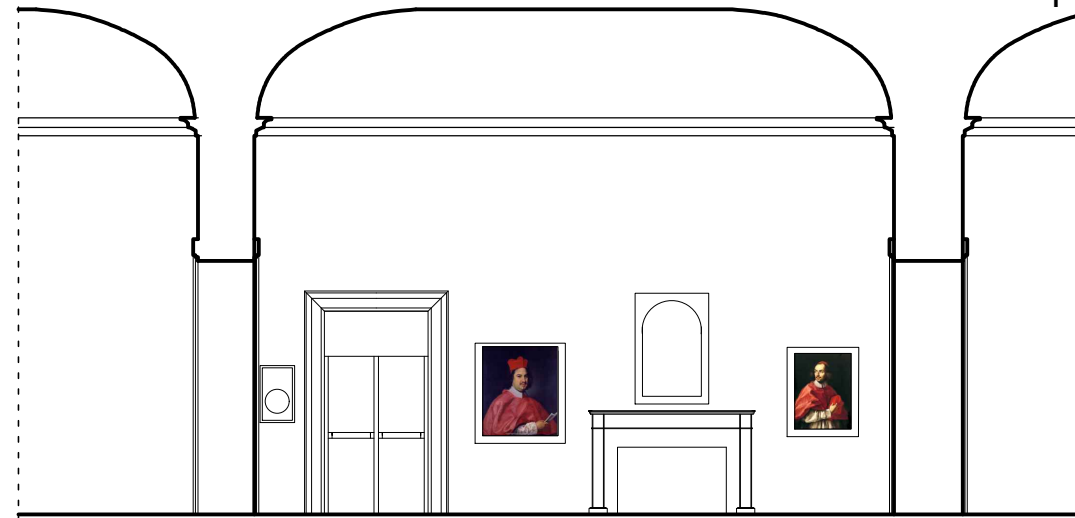

MR 1735 Ghezzi MR 45660
MR

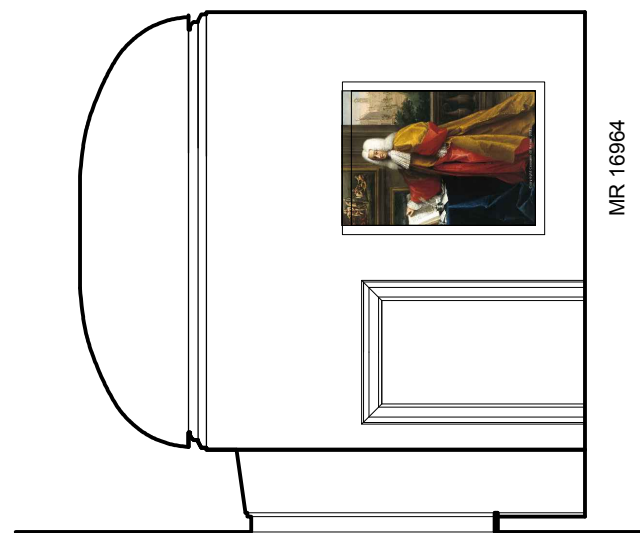

MR 16964

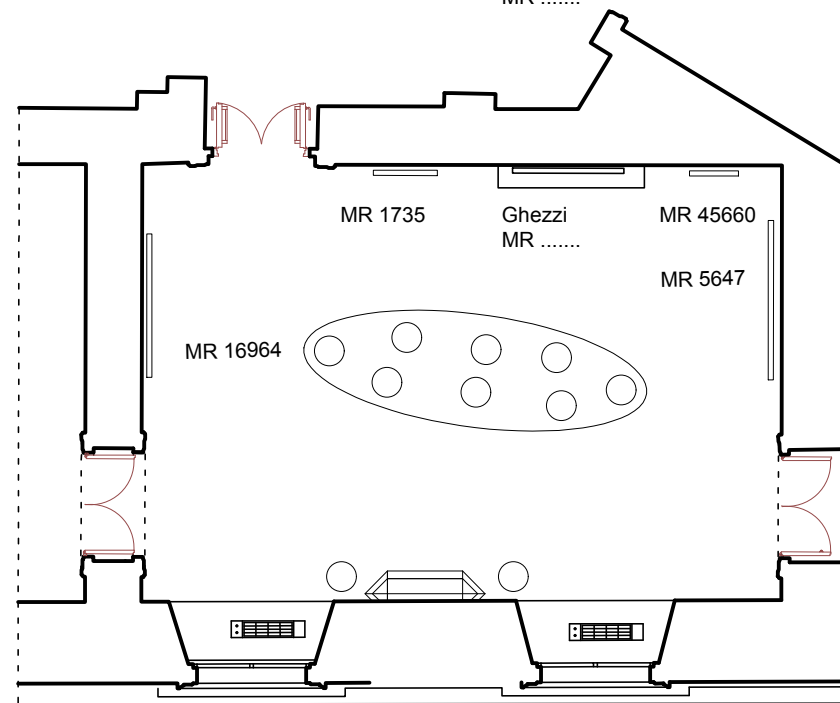

MR 1735 Ghezzi MR 45660
MR

MR 16964

MR 5647

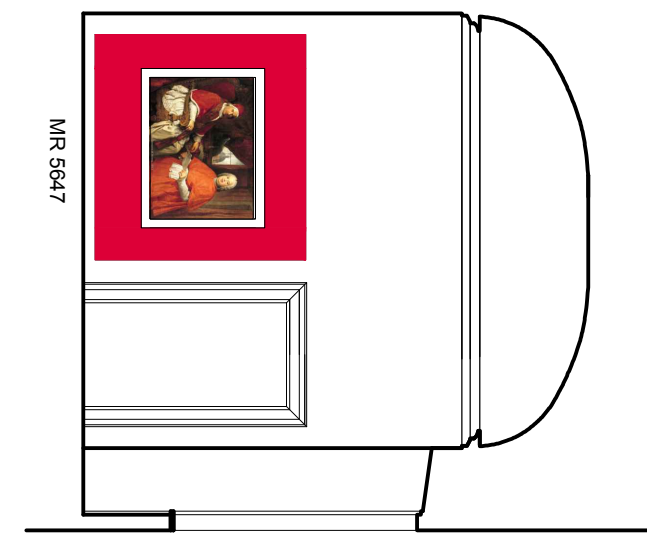

MR 5647

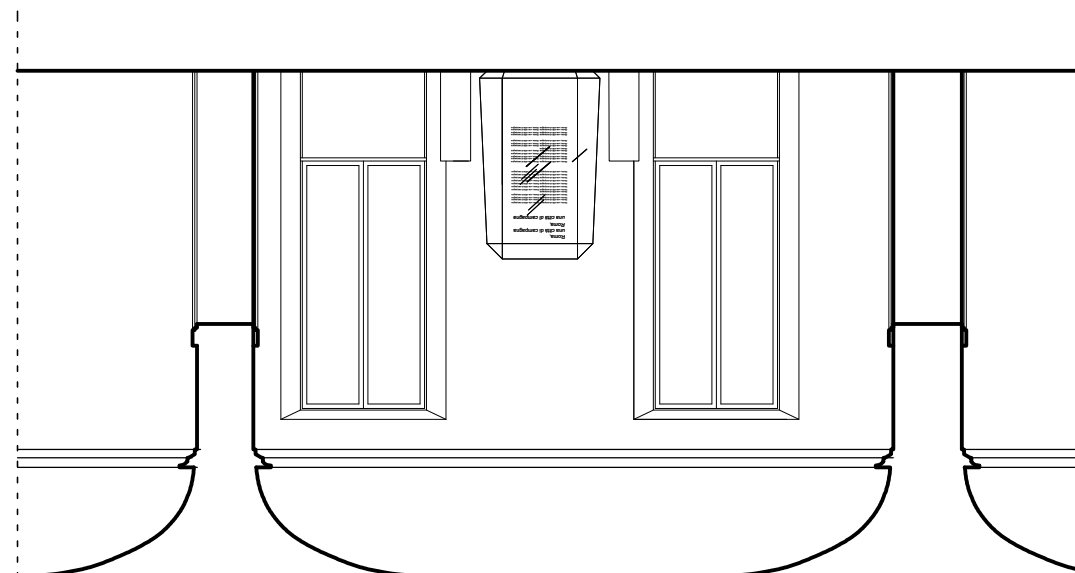

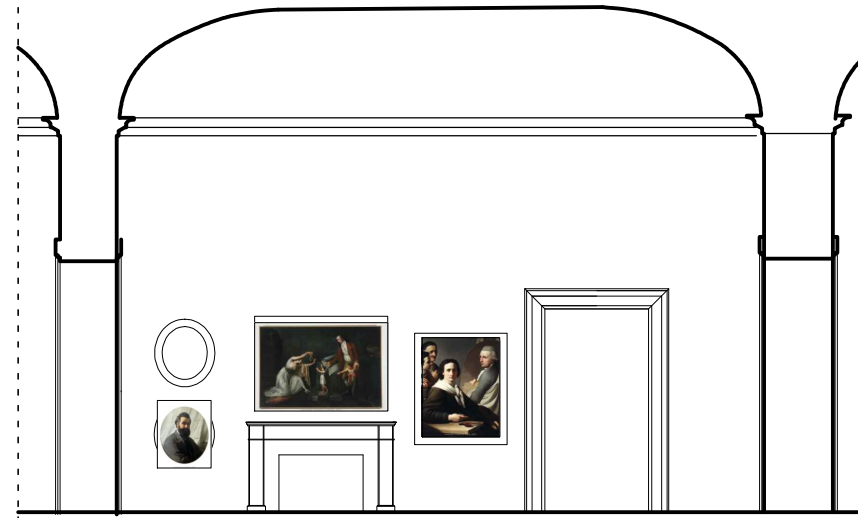

MR 45715
MR 45701 MR 169 MR 3554

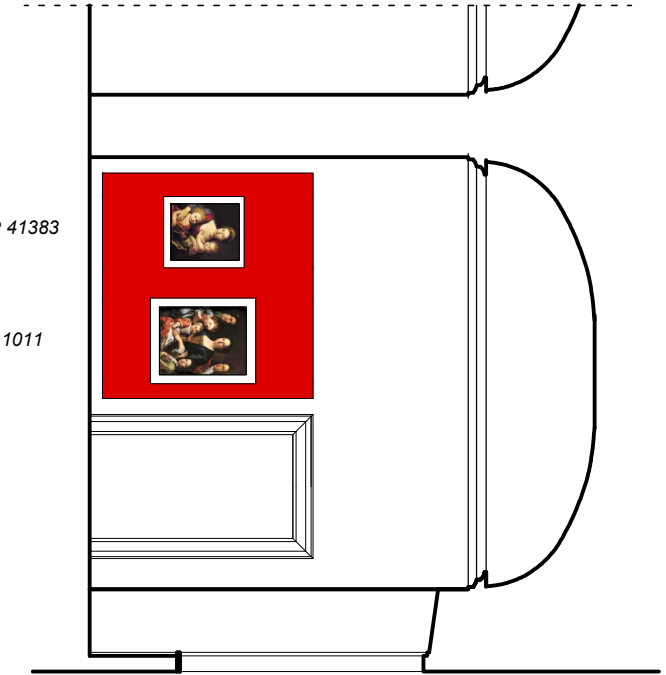
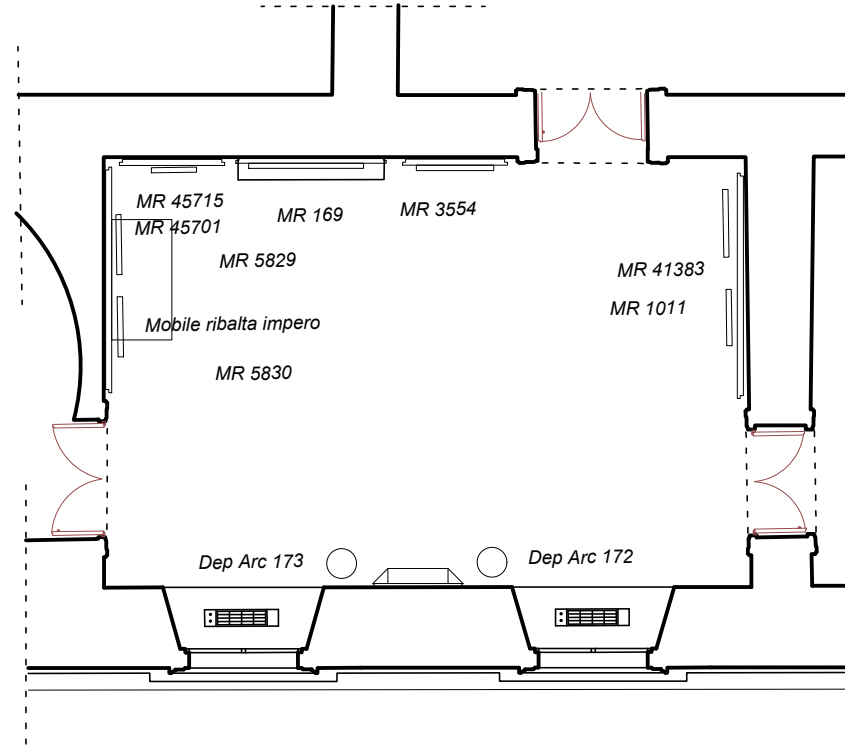
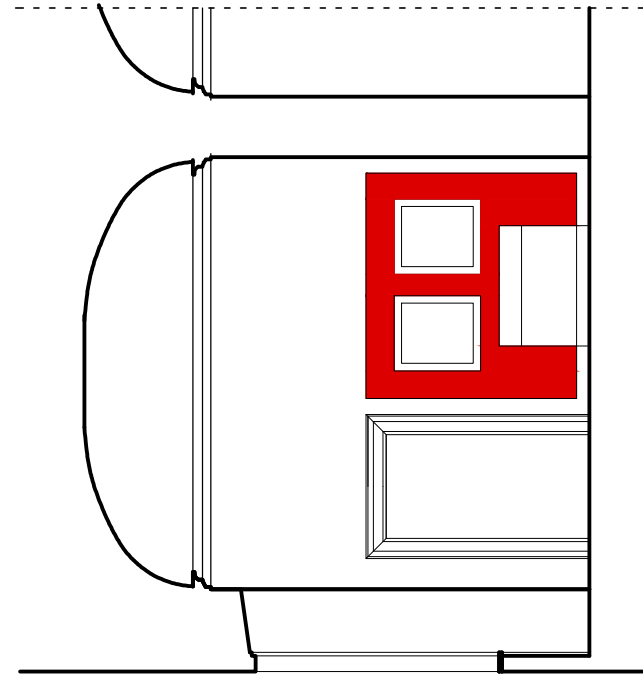



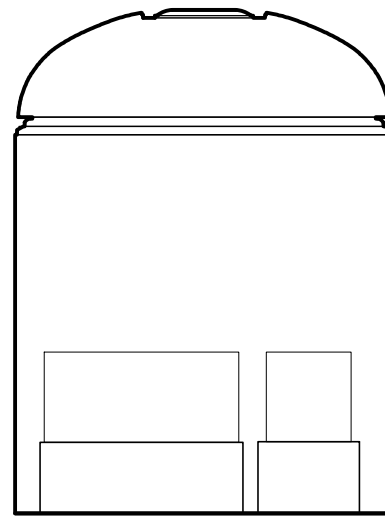

MR 43115 MR 43110

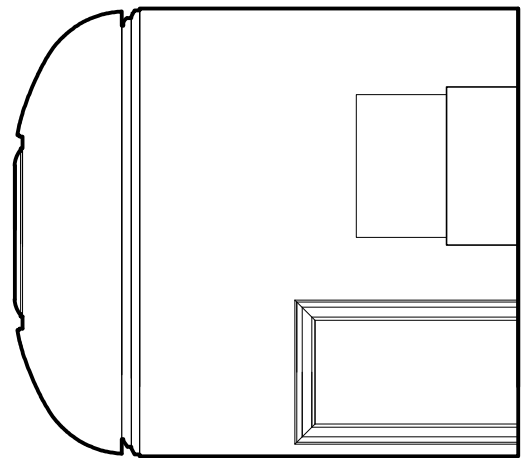

MR 43113

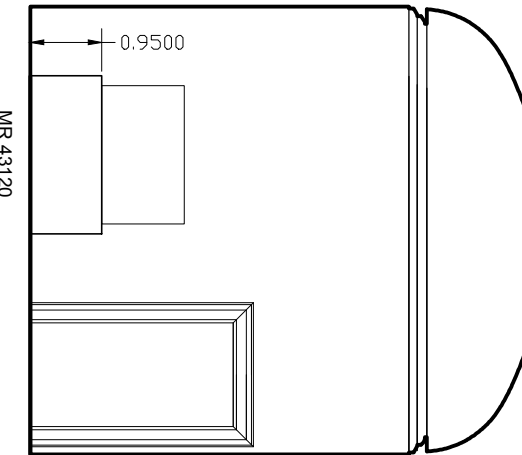
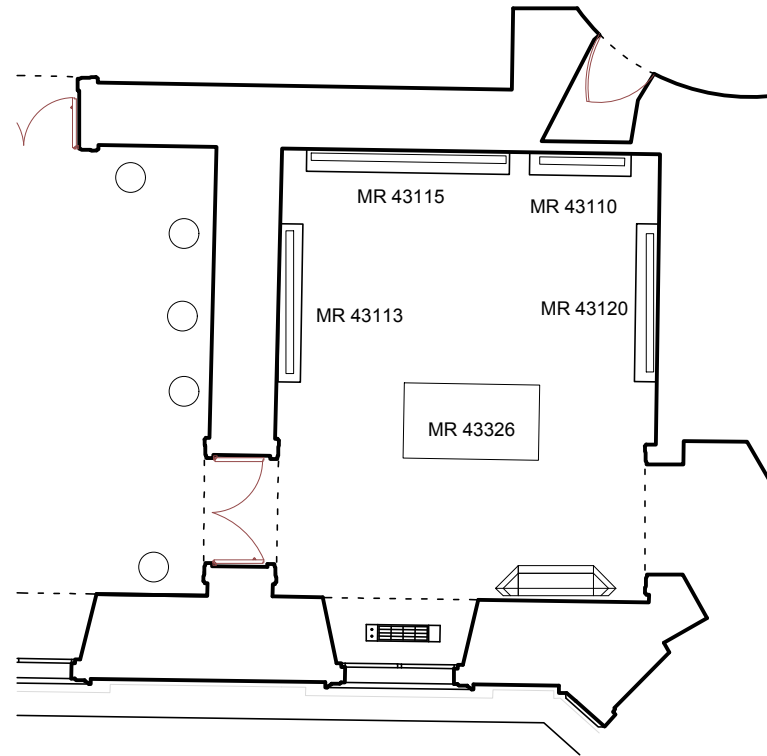

MR 43120

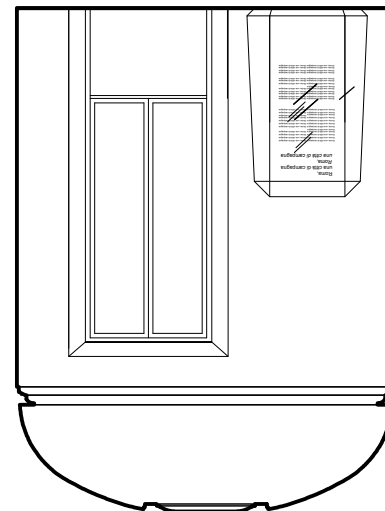

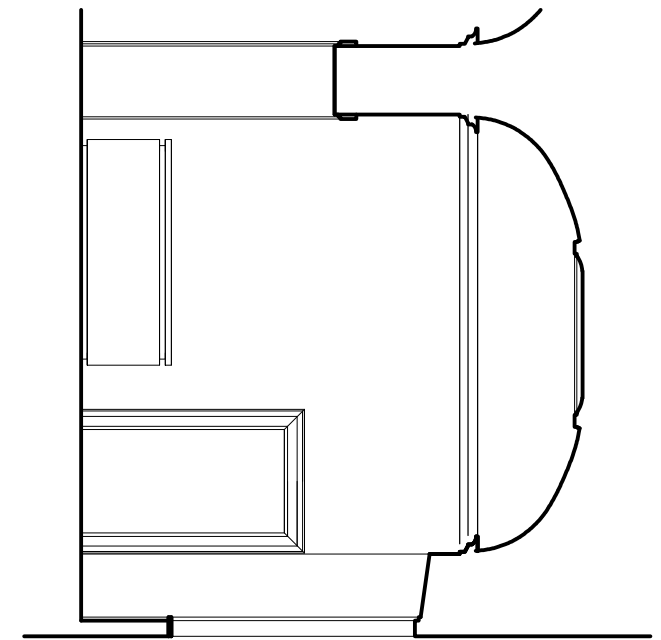
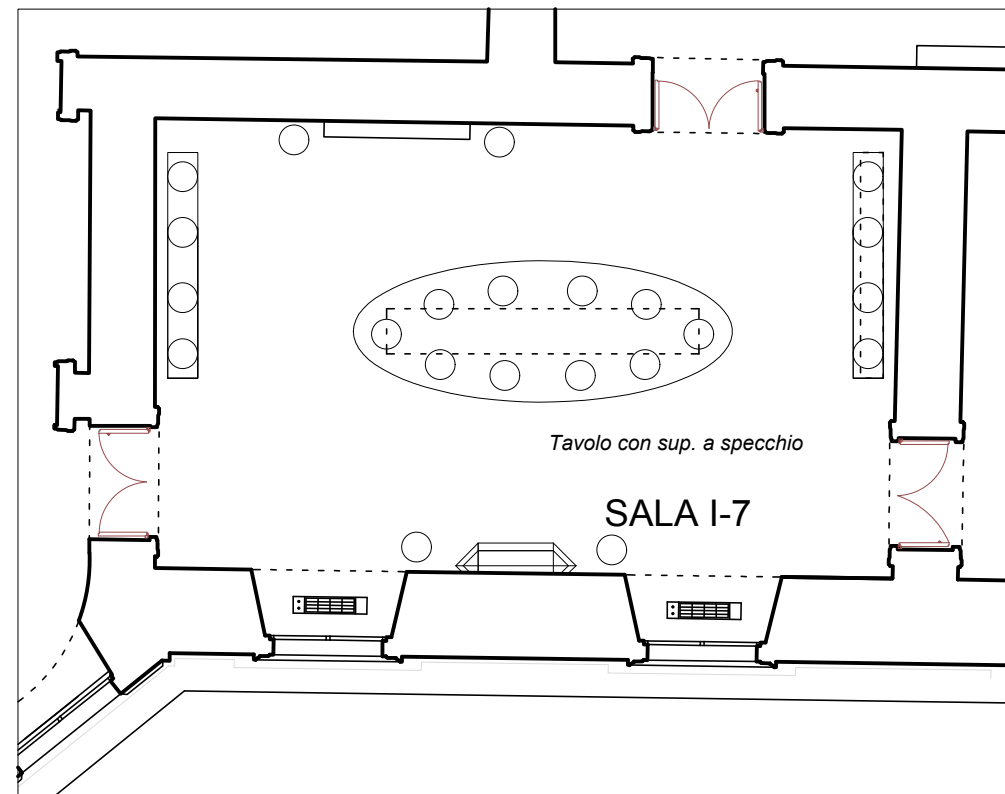
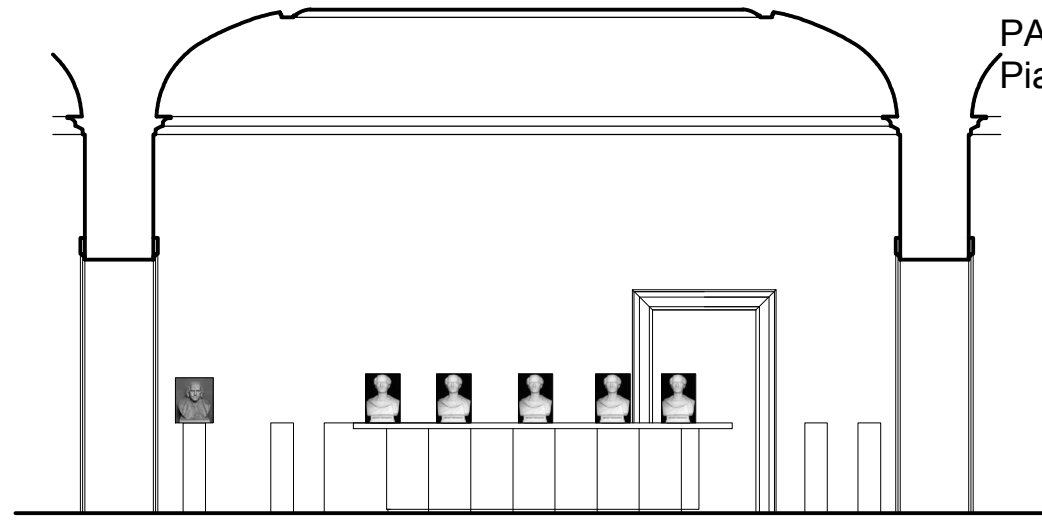
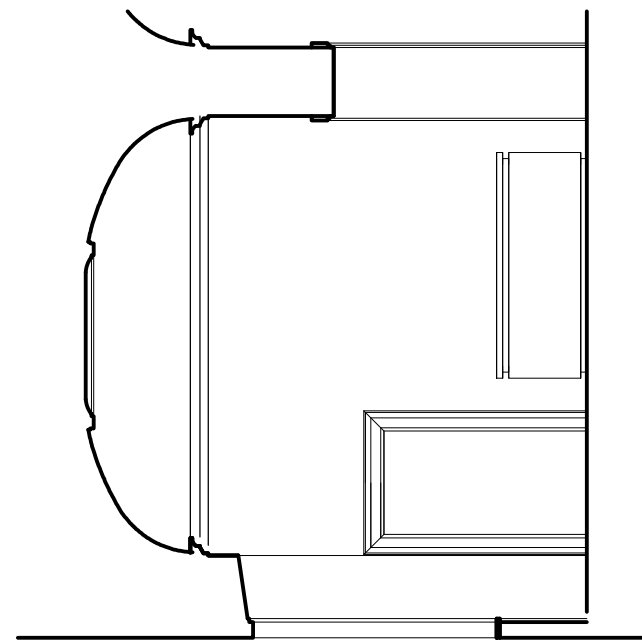

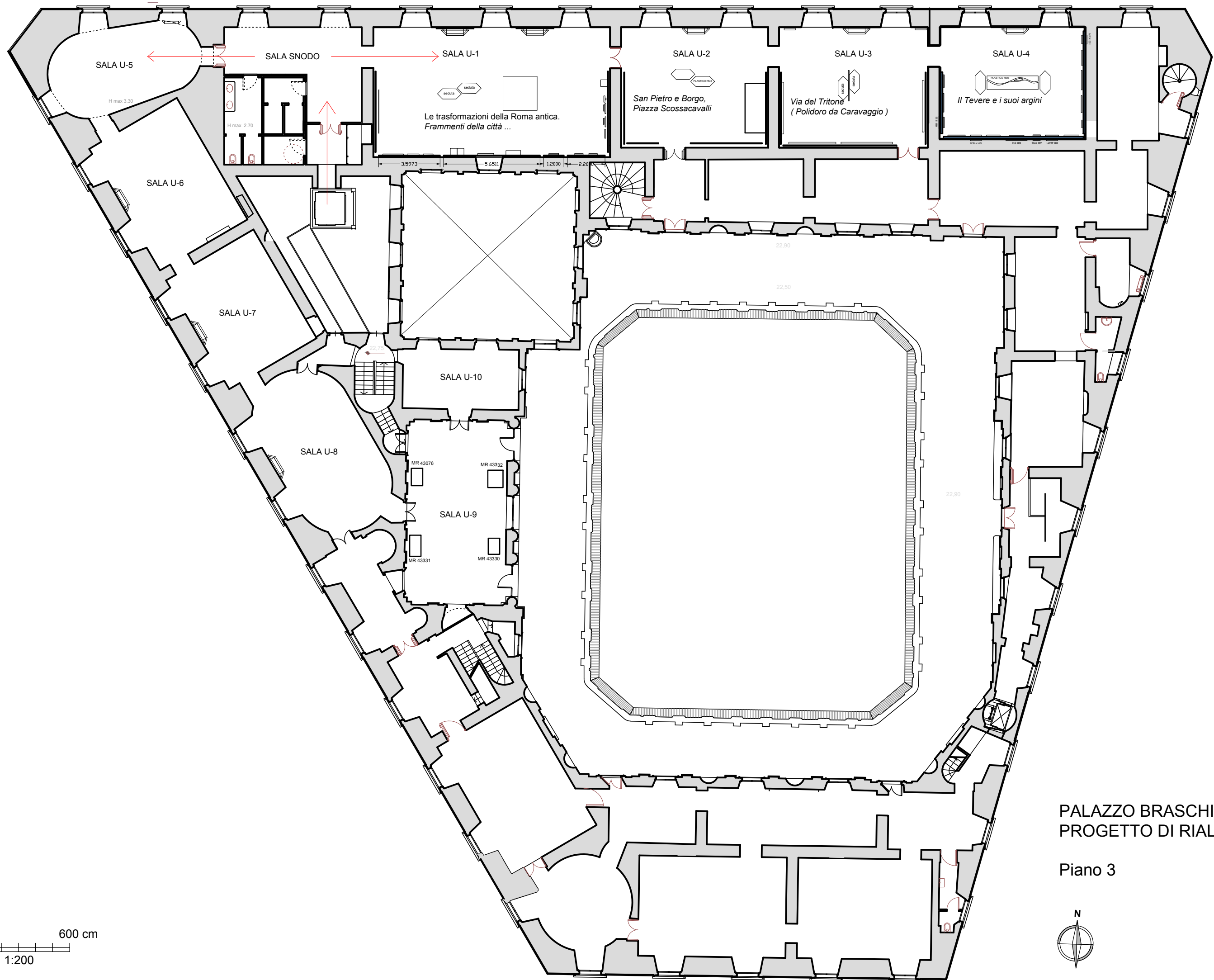

PALAZZO BRASCHI
 PROGETTO DI RIALLESTIMENTO

Piano 3



0 600 cm
 rapp: 1:200

03.0

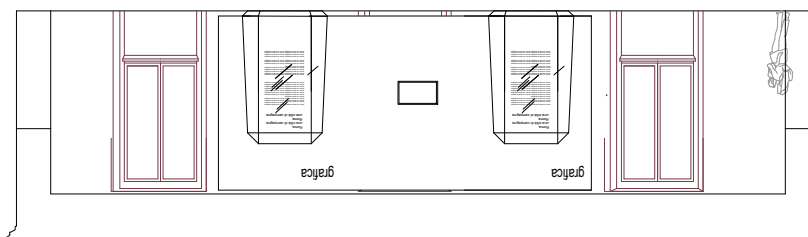
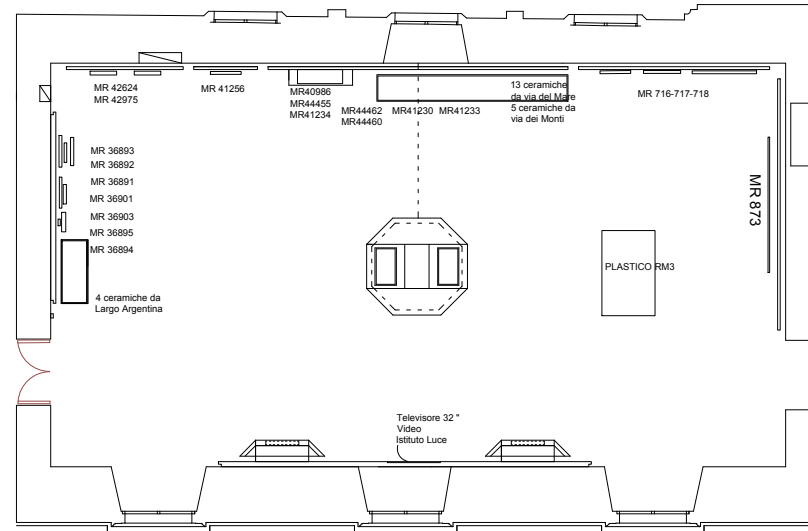
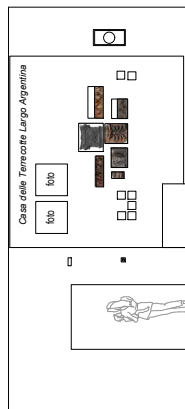
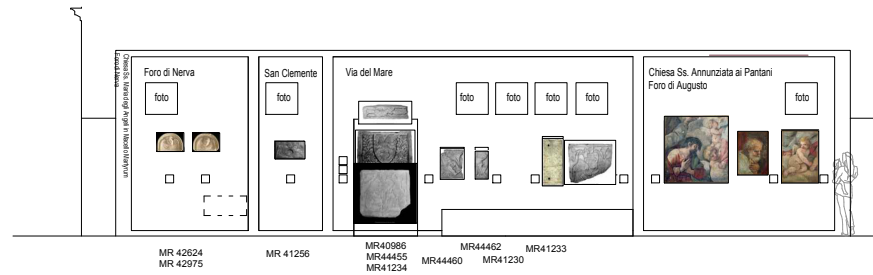

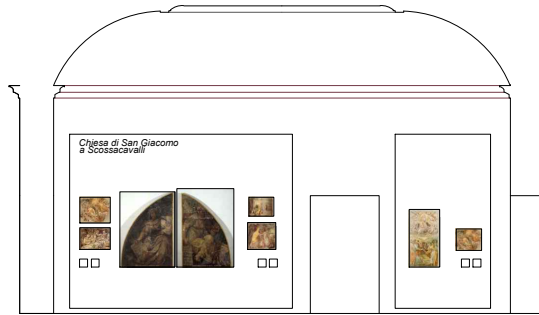

MR 1649 MR 43760 MR 1648 MR 1642
MR 1643 MR 43761 MR 1650 MR 1641

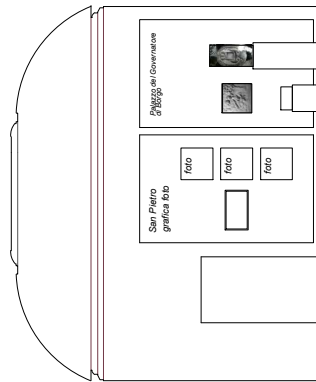

MR 45094
MR 41759
MR 44893

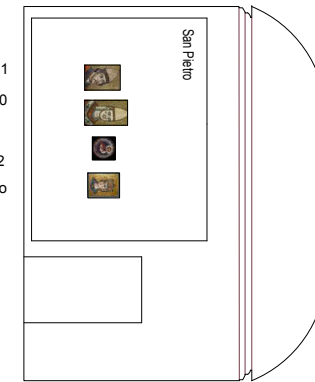
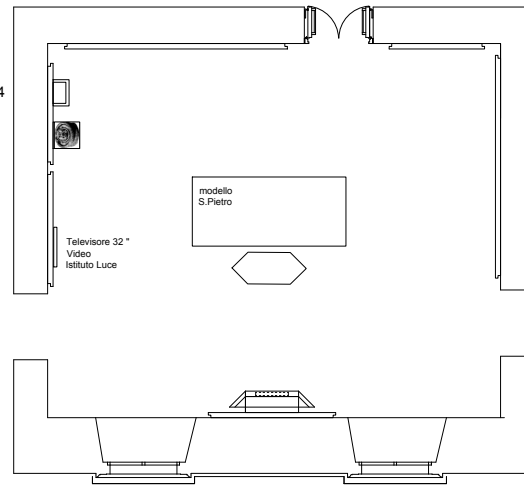

MR 5651
MR 5650
MR 5652
Barracco



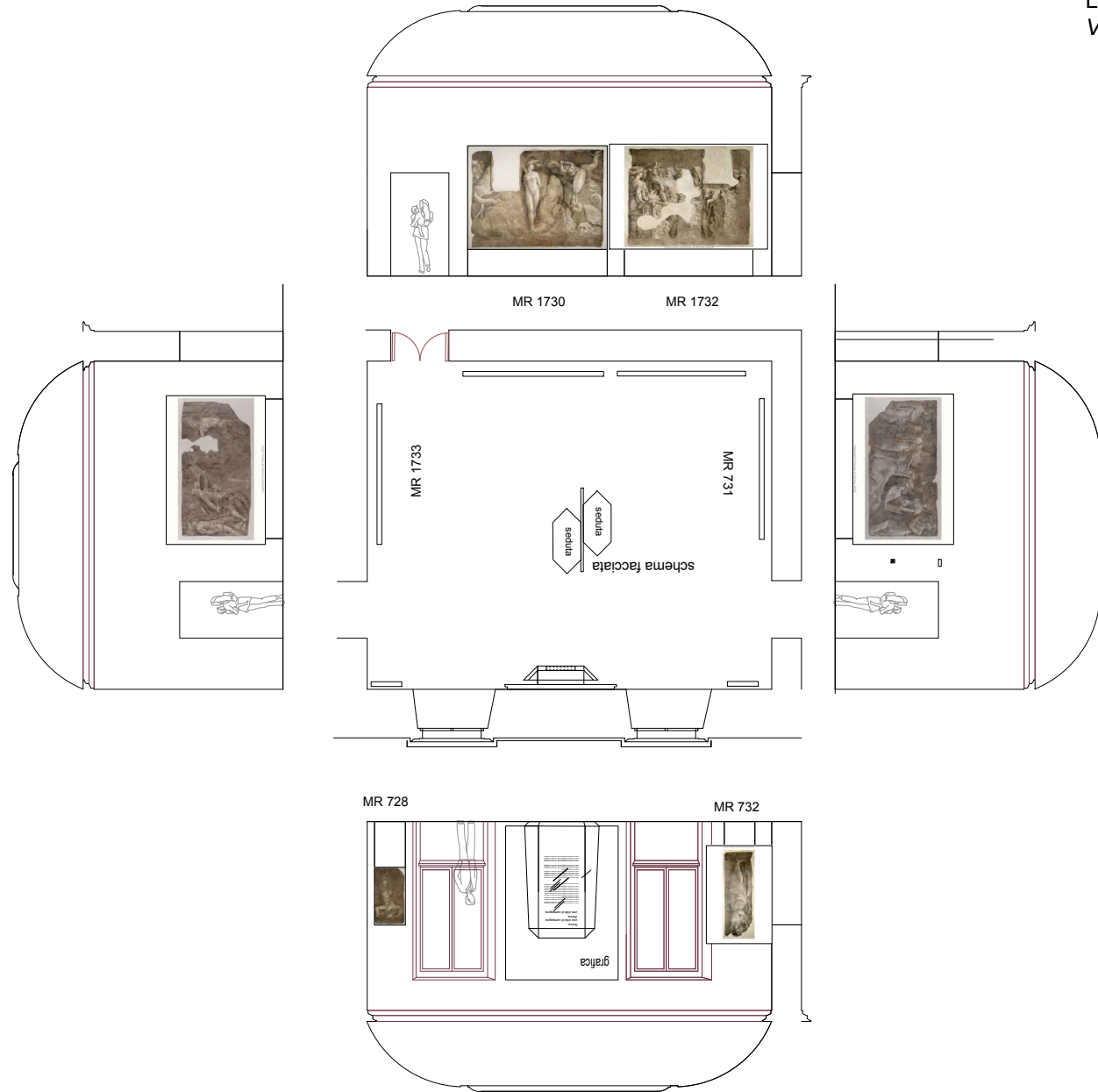

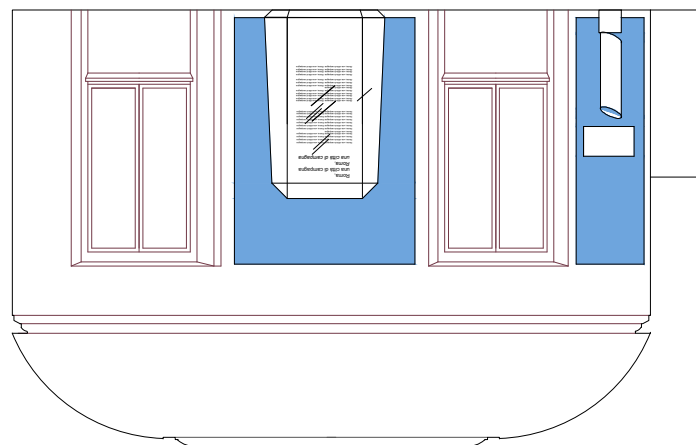
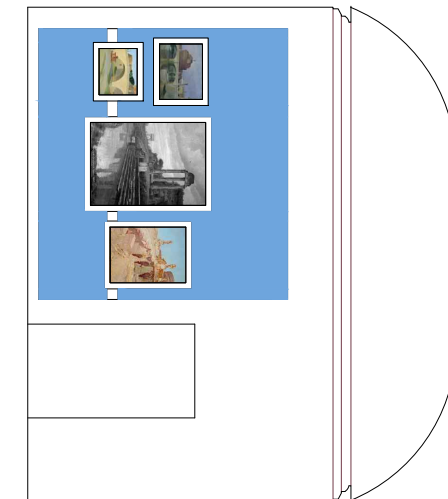
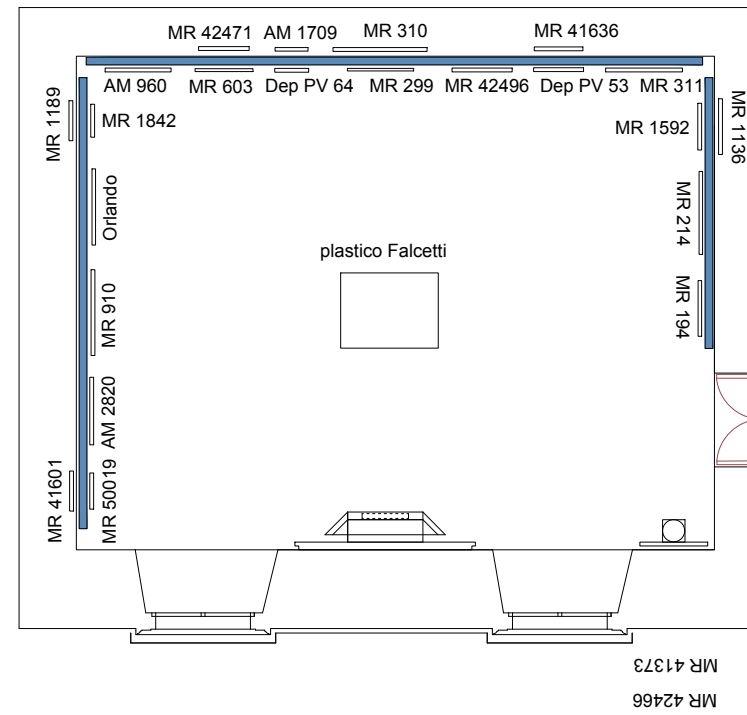
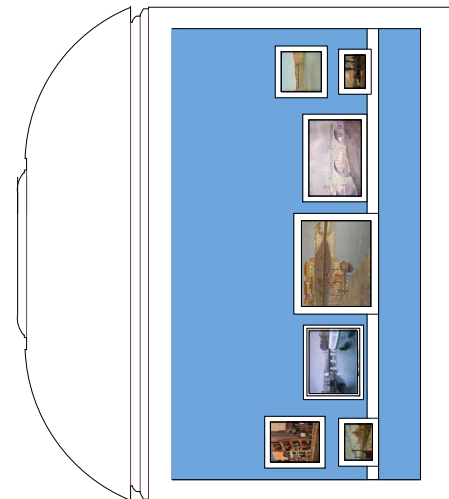
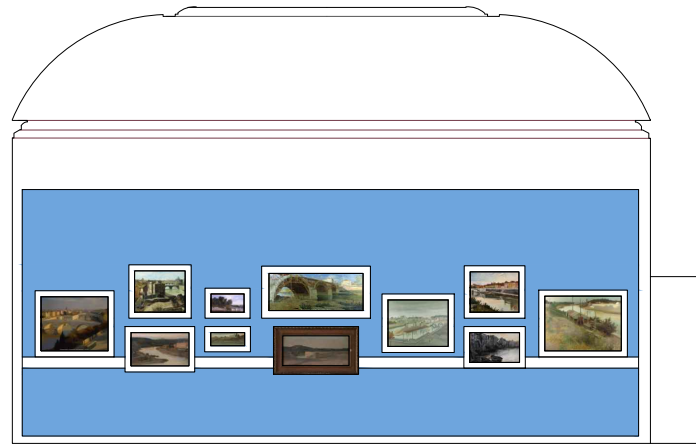

SALA SNODO

piano retroilluminato con riproduzioni fotografiche

piano retroilluminato con riproduzioni fotografiche

sala F-1

sala F-2

proiezione a parete

proiezione a parete

0 300 cm
rapp: 1:100

0 50 cm
rapp: 1:20

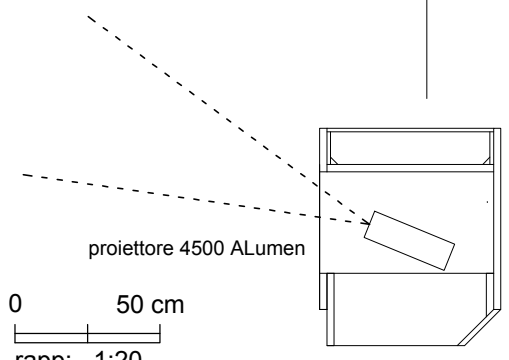

- metacrilato opalino 10mm
- stripled 14W 4400K
- rivestimento specchiante
- basamento verniciato

aggiornamento : 13/07/2016